

Konformitätserklärung
(73/23/EWG; 89/336/EWG; 98/37/EWG)
Statement of Conformity
(73/23/CEE; 89/336/CEE; 98/37/CEE)
Déclaration de conformité
(73/23/CEE; 89/336/CEE; 98/37/CEE)

Die nachfolgend bezeichnete Maschine wurde in Übereinstimmung mit den Richtlinien 73/23/EWG; 89/336/EWG und 98/37/EWG hergestellt und geprüft.

The following machine is manufactured and tested in compliance with directions 73/23/CEE; 89/336/CEE and 98/37/CEE.

La machine désignée ci-dessous est produit et examiné conforme aux directives 73/23/CEE; 89/336/CEE et 98/37/CEE

Bezeichnung der Maschine: Laborzentrifuge
Machine: Laboratory Centrifuge
Désignation de la machine: Centrifugeuse de laboratoire

Maschinentyp : 3 - 15
Type: 3 - 15
Type de la machine: 3 - 15

Bestell Nr. : 10704, 10705
Part No.: 10704, 10705
Réf. usine: 10704, 10705

Normen: EN 61010-2-020
Standards: EN 61000-3-2 ; EN 61000-3-3
Normes : EN 61326

Sigma Laborzentrifugen
An der Unteren Söse 50
D-37520 Osterode

01.02.2002

Geschäftsführer
Managing Director
Directeur Gérant

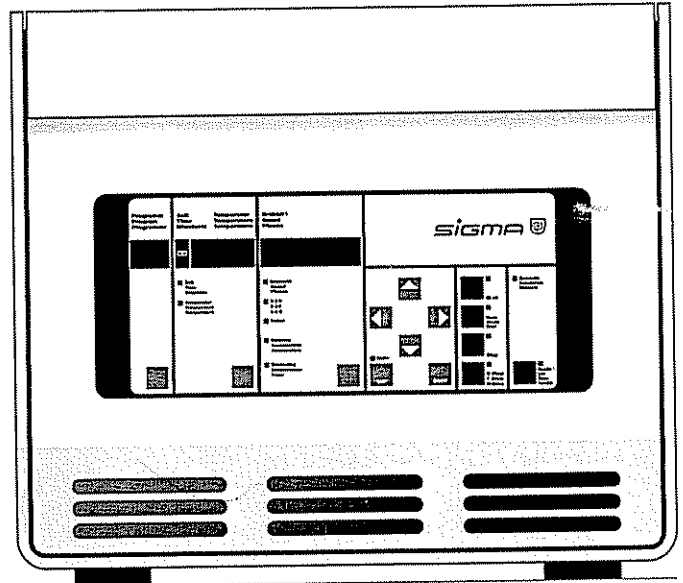

Benchtop Centrifuge

3-15

OPERATING MANUAL

Dear customer,

Congratulations for purchasing a SIGMA laboratory centrifuge. You have selected a device which combines many advantages.

A wide spectrum of programming options and an electronic operation control allow a trouble-free use of the centrifuge. With its 3-phase drive, maintenance-free quiet operation without any carbon dust pollution is guaranteed.

Your device is equipped with user-friendly options which make the operation and standard settings easier for you. Built-in error-detecting functions keep the user from entering incorrect values and check the complete operation.

A special advantage is the storage capacity the centrifuge offers. The instrument has a program memory which can store up to 10 different data sets and is also capable of keeping the last run program in its memory for an unlimited amount of time allowing the program to be restarted at any time - even if the centrifuge was turned off in between.

All settings are executed via the control panel the coated surface of which offers a clear arrangement and protects the device against moisture and dust at the same time. In addition, the interior of the centrifuge is also easy to clean. With that we are able to offer you a device that combines functional variety with practical applications.

We thank you for your confidence and wish you a successful application of the centrifuge.

SIGMA Laborzentrifugen GmbH
Postfach 1713 - D-37507 Osterode
Tel. 05522/5007-0 - Telefax 05522/500712

Internet : www.sigma-zentrifugen.de
eMail : info@sigma-zentrifugen.de

Table of Contents:

1. General Information

- 1.1 Technical data
- 1.2 Suitable accessories
- 1.3 Scope of supply
- 1.4 Standards and regulations
- 1.5 Safety instructions

2. Description of the Centrifuge

- 2.1 General outlay
- 2.2 Construction and constructive safety measures
- 2.3 Drive
- 2.4 Data input and output
- 2.5 Electronics
- 2.6 Safety devices
 - 2.6.1 Lid lock, cover closing device
 - 2.6.2 Imbalance monitoring system
 - 2.6.3 Rotor monitoring
 - 2.6.4 Standstill monitoring
 - 2.6.5 System check
 - 2.6.6 Earth wire check

3. Installation and Start-up

- 3.1 Unpacking of the centrifuge
 - 3.1.1 Transport safety device
- 3.2 Installation
 - 3.2.1 Site
 - 3.2.2 Connection
 - 3.2.3 Fuses / emergency circuit breaker on site
 - 3.2.4 Bench top fastening
- 3.3 Insertion of rotors and accessories
 - 3.3.1 Fastening of angle rotors with hermetically sealed lid
- 3.4 Initial start-up
 - 3.4.1 Switching on of the centrifuge
 - 3.4.2 Opening lid
 - 3.4.3 Insertion of rotor
 - 3.4.4 Selecting a rotor or bucket number
 - 3.4.5 Starting and stopping a run

Table of Contents:

4. Operating Elements

- 4.1 Operating panel
- 4.2 Displays and keys
- 4.3 Command panel (K)
- 4.4 Display panels
 - 4.4.1 Speed panel (D)
 - 4.4.2 Time panel (Z)
 - 4.4.3 Program panel (P)
 - 4.4.4 Monitoring panel (U)

5. Programming

- 5.1 Selection, display and alteration of program parameters
- 5.2 Changing and saving a program
- 5.3 Changing a program during centrifuge operation
- 5.4 Programming the relative centrifugal force
 - 5.4.1 Specifying a relative centrifugal force (RCF)
- 5.5 Special time preselection
 - 5.5.1 Continuous operation mode
 - 5.5.2 Short-time operation

6. Notes for Centrifugation

- 6.1 Practical notes for centrifugation
- 6.2 Forbidden centrifuging operations

7. Care and Maintenance

- 7.1 Care and cleaning of centrifuge
- 7.2 Care and cleaning of accessories
- 7.3 Rotor pins
- 7.4 Glass breakage
- 7.5 Sterilization and disinfection of rotor chamber and accessories
 - 7.5.1 Autoclaving
- 7.6 Checks by operator

Table of Contents:

8. Appendix

8.1	Slope of the specified curves, linear curves
8.2	Quadratic curves
8.3	Entry limitations
8.4	Mathematical relation
8.4.1	Relative Centrifugal Force (RCF)
8.4.2	Density
8.5	Error correction
8.5.1	Centrifuge cannot be started
8.5.2	Centrifuge decelerates during operation
8.5.3	Lid cannot be opened/closed
8.5.4	Emergency lid release
8.6	Error codes
8.7	Diagram speed/gravitational field
8.8	Declaration of decontamination/Return declaration
8.9	Form program data
8.10	Leaflet

1. General Information:

1.1 Technical Data	
Manufacturer:	S I G M A Laborzentrifugen GmbH 37520 Osterode
Type:	3-15
Electr. connection:	230 V, 50/60 Hz
Power consumption (kVA):	0,7
Rated power (kW):	0,45
Max. current consumption (A):	3,8
Power data:	
Max. speed (rpm):	14 500
Max. capacity (l):	0,8
Max. gravitational field(x g):	20 685
Max. kin. energy (Nm):	9 530
Further parameters	
Time range:	9 h, 59 min/continuous operation
Programs:	10 No. 0 - 9
Acceleration curves:	10 linear No. 0 - 9 10 quadratic No. 10 - 19
Deceleration curves:	9 linear No. 1 - 9 1 brakeless No. 0 10 quadratic No. 10 - 19
Rotor and bucket part no.:	s. chapter 1.2
Dimensions:	
Depth (mm):	550
Width (mm):	410
Height (mm):	380
Weight (kg):	37
EMC (according to EN 55011):	Class B
Noise level (dBA):	< 60
Regular checks acc. to UVV VBG 7z	no
Notes of user:	
Serial number:
Supply date:
Inventory number:
Location:
Responsibility:

The figures are valid for an ambient temperature of 23 °C +/- 2 °C and 230 Volt +/- 5 %
(Allowable ambient temperature 4 °C - 40 °C; max. humidity of air 80 %.)

1. General Information:

1.2 Accessories Suitable for SIGMA 3-15

Part No.	Description	Max. speed (rpm)	Max. gravitational field (x g)
11133	Swing-out rotor for 4 round buckets, for the following accessories	5 000	4 472
13130	Round bucket , aluminium, with thread, for 3 Falcon-tubes 15 ml, closeable with sealing cap 17111, incl. sealing ring 16251	5 000	4 472
13104	Round bucket, aluminium, with thread, for the following round carriers and the 200 ml bottles 15202 and 15203	5 000	4 332
17109	Aluminium sealing cap for hermetic sealing of buckets 13104 and 13130		
17111	Polycarbonate sealing cap for hermetic sealing of buckets 13104 and 13130		
13117	Round bucket, aluminium, for the following round carriers and the 200 ml bottles 15202 and 15203	5 000	4 332
17000	Round carrier, two-piece, indrilled, polyallomer, autoclavable		
17006	Round carrier for 12 tubes 5 ml, e.g. hemolyse tubes and RIA-tubes, Ø 12,5 x 55 up to 75 mm, e.g. 15060, polyallomer, autoclavable		
17007	Round carrier for 12 tubes 7 ml, Ø 12 x 100 mm, polyallomer, autoclavable		
17008	Round carrier for eg. 12 Eppendorf reaction vials 1,5 up to 2,2 ml, polypropylene, autoclavable		
17012	Round carrier for 6 tubes with screw cap 10 ml no. 15000, 15010 and 15019, polyallomer, autoclavable		
17013	Round carrier for 9 hemolyse tubes, max. Ø 12,9 x 85 mm, polypropylene, autoclavable		

1. General Information:

Part No.	Description	Max. speed (rpm)	Max. gravitational field (x g)
17015	Round carrier for 7 tubes 15 ml, max. \varnothing 17 x 112 mm, polyallomer, autoclavable		
17018	Round carrier for 4 tubes with sealing cap, \varnothing 17/19,4 x 107 mm (eg. Monovettes), polyallomer, autoclavable		
17019	Round carrier for 3 Falcon-tubes 15 ml, polypropylene, autoclavable, suitable for 13104 without sealing cap		
17025	Round carrier for 2 tubes 25 ml, \varnothing 24 x 100 mm, polyallomer, autoclavable		
17027	Round carrier for 7 Vacutainer-tubes, \varnothing 12/16 x 75/80 mm, polypropylene, autoclavable		
17030	Round carrier for 2 tubes with screw cap 30 ml no. 15029, 15030, 15032, 15034, polypropylene, autoclavable		
17049	Round carrier for 1 Falcon-tube 50 ml, polypropylene, autoclavable		
17050	Round carrier for 1 tube 50 ml, \varnothing 34 x 100 mm, polyallomer, autoclavable		
17052	Round carrier for 1 tube with screw cap 50 ml no. 15051, 15052, 15054, polyallomer, autoclavable		
17085	Round carrier for 1 tube with screw cap 80/85 ml no. 15074, 15075, 15076, 15080, polyallomer, autoclavable		
17100	Round carrier for 1 tube 100 ml, \varnothing 45 x 100 mm, polyallomer, autoclavable		
17101	Round carrier for 1 polypropylene tube 100 ml no. 15102, polypropylene, autoclavable		
17125	Adapter for 1 tube with screw cap 125 ml no. 15125, polypropylene, autoclavable		

1. General Information:

Part No.	Description	Max. speed (rpm)	Max. gravitational field (x g)
11132	Swing-out rotor 28 x 15 ml complete, consisting of rotor 11133, 4 round buckets 13117, 4 carriers 17015 and 28 PS-tubes 15020, max. radius 14,9 cm, min. radius 5,2 cm	5 000	4 165
11130	Swing-out rotor with support for 150 ml stainless chromium steel buckets 13100	6 000	6 118
13100	Bucket 150 ml, stainless chromium steel, suitable for 1 tube 100 ml no. 15100, 15102, 15103 with rubber cushion 16100. Attention: There is an increased risk of glass breakage at speeds exceeding approx. 5 000 rpm		
11131	Swing-out rotor 4 x 150 ml complete, consisting of rotor 11130, 4 stainless chromium steel buckets 13100, 4 rubber cushions 16100 and 4 glass tubes 15100, max. radius 13,8 cm, min. radius 5,2 cm. Attention: There is an increased risk of glass breakage at speeds exceeding approx. 5 000 rpm	6 000	5 555
11136	Rotor for reaction vials (max. 60/120 pcs.) incl. cover, for carriers 14000 and 14002, max. radius 7 cm, min. radius 3 cm. Attention: The vessels could be damaged at speeds exceeding 13 000 rpm	13 000	13 415
14000	Casset for 20 reaction vials 0,25/0,4 ml, suitable for 11136, polyallomer, autoclavable		
14002	Casset for 10 reaction vials 1,5 up to 2,2 ml, suitable for 11136, polyallomer, autoclavable		
11224	Swing-out rotor for cytology, complete, with 4 buckets and carriers for different object carriers. The buckets with object carriers could be locked in 90° position, max. radius 11,3 cm	3 000	1 140

1. General Information:

Part No.	Description	Max. speed (rpm)	Max. gravitational field (x g)
11222	Swing-out rotor incl. 2 carriers for 2 - 6 microtitre plates 86 x 130 mm, radius edge 12,1 cm, radius max. 10,5 cm, radius min. 6,5 cm	3 000	1 218 1 057 654
11223	Swing-out rotor incl. 2 carriers for 2 - 6 microtitre plates 86 x 130 mm, radius edge 11,9 cm, radius max. 10 cm, radius min. 6,5 cm	4 000	2 129 1 789 1 163
12111	Angle rotor 10 x 10 ml for sealed tubes 15000, 15010, 15019, incl. hermetic aluminium lid, max. radius 7,6 cm, min. radius 2,8 cm, angle 35°	14 500	17 865
12112	Angle rotor 12 x 15 ml for Greiner-tubes 15065, Ø 17/22 x 79/100 mm, max. radius 9,98 cm, min. radius 4,76 cm	8 000	7 141
12150	Angle rotor 6 x 50 ml for sealed tubes 15051, 15052, 15054, incl. hermetic aluminium lid, max. radius 8,4 cm, min. radius 2,1 cm, angle 25°	10 000	9 391
12110	Angle rotor 12 x 1,5 up to 2,2 ml for eg. Eppendorf reaction vials, incl. hermetic aluminium lid, max. radius 6,4 cm, min. radius 3,1 cm, angle 45 °	14 500	15 044
12154	Angle rotor 24 x 1,5 up to 2,2 ml for eg. Eppendorf reaction vials, incl. hermetic aluminium lid, max. radius 8,2 cm, min. radius 5 cm, angle 45°	14 500	19 275
12131	Angle rotor 30 x 1,5 up to 2,2 ml for eg. Eppendorf reaction vials, incl. hermetic aluminium lid, max. radius 10,0 cm, min. radius 6,7 cm, angle 45°	13 200	19 480

1. General Information:

Part No.	Description	Max. speed (rpm)	Max. gravitational field (x g)
12153	Angle rotor 36 x 1,5 up to 2,2 ml for eg. Eppendorf reaction vials, 2 lines, max. radii 8,7/7,7 cm, min. radii 5,6/4,6 cm, angle 45°	14 500	20 685/18 100
12155	Angle rotor 4 x 80/85 ml for sealed tubes 15074, 15075, 15076, 15080, incl. hermetic aluminium lid, max. radius 9 cm, min. radius 2,1 cm, angle 30°	10 000	10 062
12156	Angle rotor 8 x 50 ml for sealed tubes 15051, 15052, 15054, incl. hermetic aluminium lid, max. radius 9,4 cm, min. radius 3,3 cm, angle 25°	9 000	8 512
12157	Angle rotor 20 x 10 ml for sealed tubes 15000, 15010, 15019, incl. hermetic aluminium lid, max. radius 9,8 cm, min. radius 5,9 cm, angle 25°	9 000	8 875
12158	Angle rotor 6 x 30 ml for sealed tubes 15029, 15030, 15032, 15034, incl. hermetic aluminium lid, max. radius 7,8 cm, min. radius 2,3 cm, angle 30°	14 500	18 335
12159	Angle rotor 6 x 80/85 ml for sealed tubes 15074, 15075, 15076, 15080, incl. hermetic aluminium lid, max. radius 9,7 cm, min. radius 2,5 cm, angle 25°	8 000	6 941
19776	Angle rotor for 6 Falcon-tubes 50 ml, incl. hermetic aluminium lid, max. radius 9,3 cm, min. radius 3,1 cm, angle 25°	9 000	8 424
19777	Angle rotor for 10 Falcon-tubes 15 ml, incl. hermetic aluminium lid, max. radius 9,3 cm, min. radius 3,7 cm, angle 25°	9 000	8 424
Adapters	Tubes	Steel Tubes	
13000	Adapter , POM, for reaction vials 0,25/0,4 ml, suitable for 12110, 12131, 12153, 12154, 14002, 17008		

1. General Information:

Part No.	Description
13002	Adapter, POM, for Eppendorf reaction vials 0,5/0,75 ml, \varnothing 7,9/10 x 28/32 mm suitable for 12110, 12131, 12153, 12154, 14002, 17008
13021	Adapter for PCR-tube 0,2 ml, \varnothing 5,85/6,95 x 20/23,4 mm, suitable for 12110, 12131, 12153, 12154, 14002, 17008
15005	Eppendorf reaction vials 0,5 ml, \varnothing 7,9/10 x 28/31 mm, 1 pack contains 100 pcs., suitable for 13002
15008	Eppendorf reaction vials 1,5 ml, 1 pack contains 100 pcs., suitable for 12110, 12131, 12153, 12154, 14002, 17008
15040	Eppendorf reaction vials 2,2 ml, 1 pack contains 100 pcs., suitable for 12110, 12131, 12153, 12154, 14002, 17008
15014	Reaction vials 0,4 ml (Beckman system), polypropylene, 1 pack contains 100 pcs., suitable for 13000, 14000
15000	Teflon tube 12 ml incl. screw cap, \varnothing 16,1 x 81,1 mm, suitable for 12111, 12157, 17002, autoclavable
15010	ditto, polycarbonate, autoclavable
15019	ditto, polyallomer, autoclavable
15039	ditto, polypropylene, autoclavable
15020	Polystyrene tube 15 ml, \varnothing 17 x 100 mm, suitable for 17015
15021	Polypropylene stopper for 15020, 15023
15023	Polypropylene tube 15 ml, \varnothing 17 x 100 mm, suitable for 17015
15065	Greiner tube 15 ml incl. cap, \varnothing 17/22 x 79/100 mm (Greiner no. 187261), suitable for 12112

1. General Information:

Part No.	Description
15029	Teflon tube 28 ml incl. screw cap, Ø 25,3 x 92 mm, suitable for 12158, 17030, autoclavable
15030	Polycarbonate tube 32 ml incl. screw cap, Ø 25,3 x 92 mm, suitable for 12158, 17030, autoclavable
15032	Polypropylene tube 28 ml incl. screw cap, Ø 25,3 x 92 mm, suitable for 12158, 17030, autoclavable
15034	Polyallomer tube 30 ml incl. screw cap, Ø 25,3 x 92 mm, suitable for 12158, 17030, autoclavable
13055	Bucket 50 ml, stainless chromium steel, closeable with sealing cap 17054, Ø 28/34,5 x 101,5/104,5 mm, suitable for 12150, 12156, 17052
17054	Sealing cap, stainless chromium steel, for 13055
15049	Polycarbonate tube 50 ml, graduated, Ø 34 x 100 mm, suitable for 17050
15051	Teflon tube 42 ml incl. screw cap, Ø 28,5 x 107 mm, suitable for 12150, 12156, 17052, autoclavable
15052	Polypropylene tube 42 ml incl. screw cap, Ø 28,5 x 107 mm, suitable for 12150, 12156, 17052, autoclavable
15054	Polycarbonate tube 40 ml incl. screw cap, Ø 28,5 x 107 mm, suitable for 12150, 12156, 17052, autoclavable
13085	Tube 85 ml, stainless chromium steel, closable with sealing cap 17185, Ø 38,2/40 x 100/107 mm, suitable for 12155, 12159, 17085
17185	Sealing cap, stainless chromium steel, for 13085

1. General Information:

Part No.	Description
15074	Polycarbonate tube 73 ml incl. special screw cap made of aluminium with seal for high speeds, Ø 38 x 108 mm, suitable for 12155, 12159, 17085, autoclavable
15075	Polycarbonate tube 73 ml incl. screw cap, Ø 38 x 112 mm, suitable for 12155, 12159, 17085, autoclavable
15076	Polypropylene tube 72 ml incl. screw cap, Ø 38 x 112 mm, suitable for 12155, 12159, 17085, autoclavable
15080	Polyflor tube 74 ml incl. screw cap, Ø 38 x 112 mm, suitable for 12155, 12159, 17085, autoclavable
15102	Polypropylene tube 100 ml, Ø 45 x 100 mm, suitable for 17101, 13100
15103	ditto, polycarbonate, suitable for 13100, 17100, 17101, graduated
15125	Polypropylene tube 125 ml incl. screw cap, Ø 50,5 x 99 mm, suitable for 17125
15202	Polypropylene bottle 200 ml incl. screw cap, Ø 56,5 x 113 mm, suitable for 13104, 13117
15203	ditto, polycarbonate

Glass Tubes

15007	Glass tube 7 ml, Ø 12 x 100 mm, suitable for 17007
15027	ditto, graduated
15015	Glass tube 15 ml, Ø 16 x 100 mm, suitable for 17015
15024	ditto, graduated

1. General Information:

Part No.	Description
15022	Special glass tube 15 ml, \varnothing 17 x 105 mm, suitable for 12150, 12156 with 16018 and for 12155, 12159 with 16019, max. speed 7 000 rpm
15025	Glass tube 25 ml, \varnothing 24 x 100 mm, suitable for 17025
15026	ditto, graduated
15033	Special glass tube 30 ml, \varnothing 24 x 105 mm, suitable for 12150, 12156 with 16030 and for 12155, 12159 with 16031, max. speed 7 000 rpm
15050	Glass tube 50 ml, \varnothing 34 x 100 ml, suitable for 17050
15056	ditto, graduated
15100	Glass tube 100 ml, \varnothing 44 x 100 mm, suitable for 13100, 17100, 17101
15106	ditto, graduated

Further Accessories

16018	Rubber adapter for 15 ml glass tube 15022, suitable for 12150, 12156
16019	Rubber adapter for 15 ml glass tube 15022, suitable for 12155, 12159
16030	Rubber adapter for 30 ml glass tube 15033, suitable for 12150, 12156
16031	Rubber adapter for 30 ml glass tube 15033, suitable for 12155, 12159
16100	Rubber cushion for stainless chromium steel bucket 13100
16910	Rubber plate for round carriers 17006, 17007, 17012, 17015, 17025
16911	Rubber plate for round carriers 17050, 17100

1. General Information:

Part No.	Description
17111	Round polycarbonate sealing cap, clear, for bucket 13104, 13130
16251	Sealing ring 57 x 2 x 3 mm for bucket 13104, 13130
17971	Tool to remove the microtitre plates from rotors 11222, 11223
17914	Table for centrifuge made of chipboards with 2 doors and space for accessories, movable on lock-type castors, dimensions: w 650, d 680, h 470 mm The rubber feet of the centrifuge must be replaced by other feet.
17913	Fasteners for table 17914

Maximum speed for tubes

Some tubes, e.g. centrifuges glass tubes, microtubes, Falcon tubes, Teflon tubes and especially high volume tubes can be used in our rotors, buckets and adapters at higher speeds than their breaking limit. We recommend to always fill up the tubes and to follow the recommendations of the manufacturer.

1. General Information:

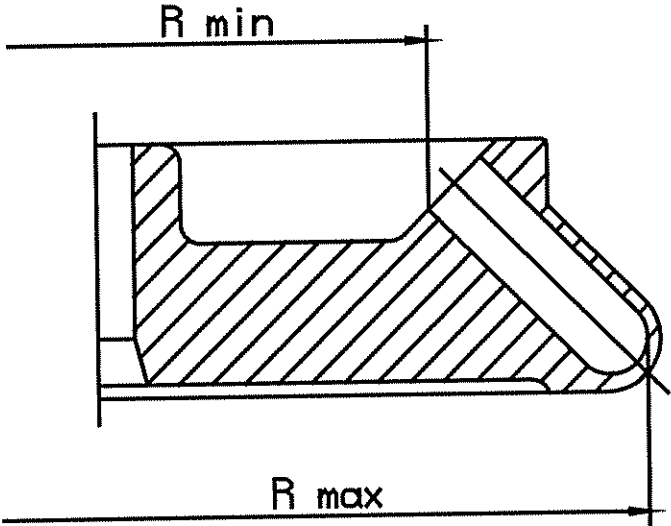
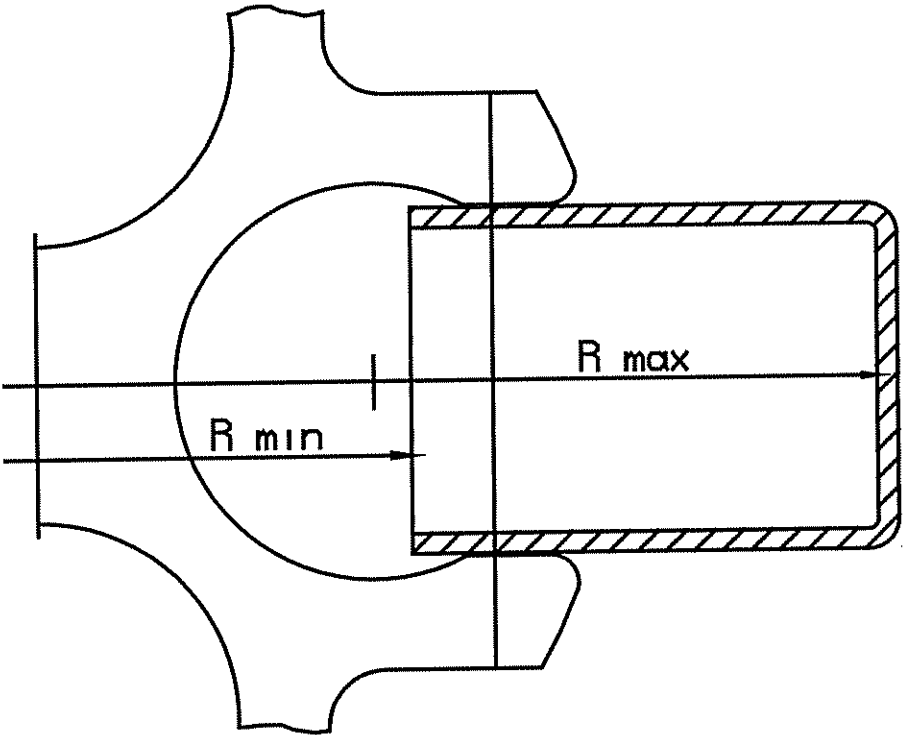

1. General Information:

1.3 Scope of Supply

The following belongs to the centrifuge:

- | | |
|---------------------------------------|------------------|
| 1 Rotor spanner SW 10 | Part No. 930 100 |
| 1 Tube grease for rotor trunnion pins | Part No. 70 284 |
| 20 ml slushing oil | Part No. 70 104 |

Documentation:

- 1 Short operating instructions
- 1 Operating instructions
- 1 "Rotor and Accessories, Operation and Use"
- 1 EU-Statement of Conformity
- 1 Equipment Decontamination Certificate

Accessories according to your order, our order confirmation and our delivery note.

Rotor Part No.	Rotor No.
.....
.....
.....
.....
.....
.....
.....

1. General Information:

1.4 Standards and Regulations

Please refer to the enclosed EU-Statement of Conformity.

1. General Information:

1.5 Safety Instructions

regarding operation of centrifuges with rotors of different max. speed, eg. angle rotors and swing-out rotors.

According to the German health and safety regulation UVV, VBG 7z the operator should take care of the following points:

1. According to § 19 of the UVV, VBG 7z the owner has to provide operating instructions based on those of the manufacturer and to inform the employees accordingly.
2. For safety reasons these operating instructions must clearly state that the stamped max. speed of the used rotor/bucket and the max. allowable filling quantity must not be exceeded.
3. If the density of the material exceeds 1.2 g/cm^3 , the max. speed of the centrifuge must be reduced respectively the instrument's control electronics automatically reduces the selected speed when a density of higher than 1.2 g/cm^3 is entered.
4. Operation of the centrifuge in hazardous locations is not allowed.
5. During operation the centrifuge must not be moved. Leaning against or resting on the centrifuge is not allowed.
6. Do not spin explosive or highly inflammable materials.
7. Substances which could damage the material of the centrifuge, the rotors or the buckets anyhow must not be centrifuged or only under consideration of special safety measures. Infectious, toxic, pathogene or radioactive substances must be centrifuged in suitable rotors only.
8. Keep a clearance of at least 30 cm around the centrifuge. Dangerous materials of any kind must not be put down or stored in that area.
9. Attention!
Defective lid relieving devices could cause the centrifuge lid to fall down (contact Service). Risk of bruising!

2. Description of Centrifuge:

2.1 General Outlay

The new generation of SIGMA laboratory centrifuges is equipped with newest state-of-the-art electronics and is driven by brushless, silent and long-life asynchronous motors.

The problem of carbon brush change is no longer existent and as there is no carbon dust pollution, operation in clean rooms is possible if the appropriate accessories are used.

2.2 Construction and Constructive Safety Measures

The centrifuge is built into an aluminium sheet housing. The opening to the rotor chamber is smaller than the chamber itself providing additional safety in the event of an accident. The centrifuge lid is also made of solid aluminium sheet steel. From the back the lid is secured by solid shafts and at the front by a cover lock.

The bottom of the barrier ring is a multiple steel plate so that there is a solid safety case around the rotor chamber. The centrifuge stands on noise absorbing, elastic feet with optional devices for bench top fastening.

2.3 Drive

The drive motor is a well dimensioned asynchronous motor.

As there are no commutators, no carbon brush change is necessary, there is no carbon dust pollution and the noise level is low.

2.4 Data Input and Output

The input and output unit is a hermetically sealed foil keyboard with clearly distinguished keys. Easily readable displays and LED's are available and lead the operator through the wide range of applications.

Option:

A connection for a serial interface is possible so that an external personal computer with printer can be connected for control or recording.

2. Description of Centrifuge:

2.5 Electronics

The electronics controlled by a microprocessor allows extensive adaptations of the centrifuge to the different tasks. The following parameters can be programmed and called among others:

- Speed in steps of 1 rpm
- RCF in steps of 1 x g
- Continuous and time operation (9 h, 59 min) in steps of 1 min
- Short-time operation
- Fixed deceleration and acceleration curves
- Error messages recognized by the system and saved for service

2.6 Safety Devices

Apart from the passive safety devices due to the instrument's mechanical design there are the following active precautions for your safety:

2.6.1 Lid Lock, Cover Closing Device

The centrifuge can only be started when the lid is correctly closed. The cover lock must close. The lid can only be opened when the rotor has stopped. If the lid is opened by the emergency release during operation, the centrifuge will immediately switch off and decelerate brakeless. If the lid is open, the drive is completely separated from the mains supply, that means starting of the centrifuge is impossible (refer to point 8.5.4 "Emergency lid release").

2.6.2 Imbalance Monitoring System

In the event that uneven loading leads to imbalance, the drive is switched off during acceleration or during run.

2.6.3 Rotor Monitoring

During programming the rotor part no. and if required the bucket part no. must be entered. The computer checks, if the entered speed or the gravitational field is allowed for the rotor. Input errors are impossible (refer to point 8.3 "Entry limitations"). After starting, during the start-up phase, the computer additionally checks the identity of the rotor. **Attention: Please take care to enter the correct bucket part no. as the max. allowable speed could be exceeded by entering an incorrect bucket. This is not allowed.** If the rotor doesn't correspond to the programmed rotor no., STOP is carried out and an error message is issued. Restarting the centrifuge is only possible, when the rotor part no. has been corrected.

2. Description of Centrifuge:

2.6.4 Standstill Monitoring

Opening of the centrifuge lid may only be possible, if the rotor is at standstill. This standstill is checked by the microprocessor and also by a second additional hardware circuit. Both monitoring devices must independently of each other have recognized that the rotor is at standstill before the lid can be opened.

2.6.5 System Check

An internal system check monitors data transmission and the sensor signals with regard to plausibility. The diverse malfunctions are recognized with utmost sensitivity, displayed as error message together with an error number and saved for service.

2.6.6 Earth Wire Check

For earth wire check there is a potential equalization screw at the rear panel of the centrifuge. An earth wire check can be carried out using an appropriate measuring instrument.

3. Installation, Start-up:

3.1 Unpacking of the Centrifuge

Open cardboard. Take out box containing accessories. Remove upper foam cushions. Lift centrifuge upwards with two persons. When lifting or carrying the centrifuge please always reach under the instrument from the side.

Please keep case for possible transport of centrifuge later.

3.1.1 Transport Safety Device

The SIGMA 3-15 has a transport safety device. Please remove the plastic cap from the centrifuge chamber and keep it for possible transport of the centrifuge.

3. Installation, Start-up:

3.2 Installation

3.2.1 Site

All energy consumed by the centrifuge is converted into heat and emitted into the ambient air. Therefore, sufficient ventilation is important. The air-ducts in the unit must be open. Also, the centrifuge shouldn't be positioned near radiators and direct insulation should be avoided.

A clearance of at least 30 cm around the centrifuge is necessary.

For normal operation the ambient temperature should not fall below 4 °C and not exceed 40 °C. The max. humidity of air is 80 %. During transport from cold to warmer places there will arise condensation water inside the centrifuge. It is important that there is enough time for drying before the centrifuge can be started again.

3.2.2 Connection

The operating voltage on the name plate must correspond to the local supply voltage!

SIGMA laboratory centrifuges are units of safety class I, DIN VDE 0700, and include a three wire power cord 2,5 m long with shockproof right angle plug.

3.2.3 Fuses /Emergency Circuit Breaker on Site

The centrifuges must be protected typically with at least 16 A slow acting fuses.

An emergency circuit breaker to cut the power to the centrifuge in the event of a malfunction is required on site. This switch should be located away from the centrifuge, preferably outside the room where the centrifuge is used or at the exit of this room.

3.2.4 Bench Top Fastening

A special device for bench top fastening is available on request.

3. Installation, Start-up:

3.3 Insertion of Rotors and Accessories

1. Open centrifuge lid by pressing Lid-key K5.
2. Unscrew rotor tie-down screw from motor shaft (anticlockwise).
3. Lower the rotor straight down onto the motor shaft.
4. Tighten the tie-down screw (clockwise) with the rotor spanner so that the disc spring, if existing, is pressed together.

Fastening torque: 110/112/113/203/204/1K 15/2-15/2K 15: approx. 5 Nm
3-15/3K 15/3K 18/3K 30: approx. 7,5 Nm
4-10/4K 10/6-10/6K 10: approx. 10 Nm

In the event of frequent use the tie-down screw must be loosened by some turns and fastened again. **This should be done once a day or after approx. 20 cycles.** This ensures a proper connection between rotor and shaft (please refer to chapter 7.2 "Care and cleaning of accessories" as well).

5. Fill all positions of swing-out rotors with buckets. Take care of correct installation of buckets.

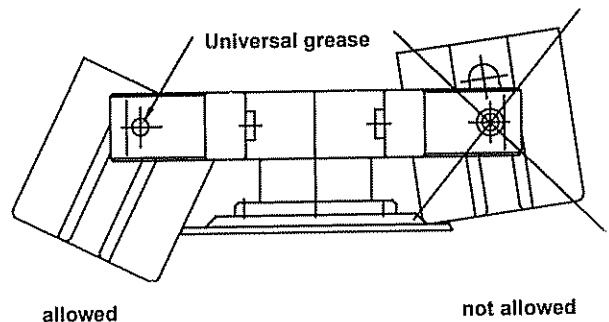

6. Use only appropriate vessels for the rotor (please refer to chapter 1.2 "Suitable accessories" as well).

7. Fill vessels external to the centrifuge.
8. Put or screw on covers of vessels.
9. Opposite places of the rotors must always be loaded with same accessories and same filling.
10. In angle rotors the plastic vessels must always be totally filled to avoid distortion of vessels and leakages or loosening of the caps in case of partial filling. **Attention**, follow the special comments of chapter 1.5.
11. Attention: The centrifuge will absorb smaller differences in weight when loading the rotors. But it is recommended to balance the vessels as accurately as possible in order to ensure a run with minimal vibrations. Should the centrifuge be operated with very uneven load, the imbalance device will switch off the drive and an error message appears on the display.

3. Installation, Start-up:

The LED Imbalance (U3) of the monitoring panel is flashing (refer to 4.1 folding illustration at the end of the operating instructions).

12. Rotors with cover should always be run with their covers. The rotor cover is tightened with the rotor spanner. Correct fastening must be ensured. **Attention: The cover screw serves for fastening of the cover onto the rotor only, not for fastening of the rotor onto the drive!** Before installation of cover, the correct fastening of the rotor fixing screw must always be checked using a spanner.

3.3.1 Fastening of Angle Rotors with Hermetically Sealed Lid

1. Screw rotor cover (2) onto rotor and tighten it.
2. Lower rotor with cover (2) onto motor shaft.
3. Put rotor tie-down screw (1) onto motor shaft and tighten using the spanner.
4. The rotor can be run without cover (2) as well.
5. The rotor and cover seals (3) must be greased after cleaning.
6. Special instructions for the use of hermetically sealed rotors:

All rotors can be installed or removed with closed cover after loosening the rotor tie-down screw. All rotors are autoclavable (refer to chapter 7.6 "Sterilization and disinfection of rotor chamber and accessories"). To increase life of rotors and seals the rotors must be greased with slushing oil and the seals and thread areas with vaseline or grease after cleaning.

Attention!

Please follow the special comments of chapter 1.5.

3. Installation, Start-up:

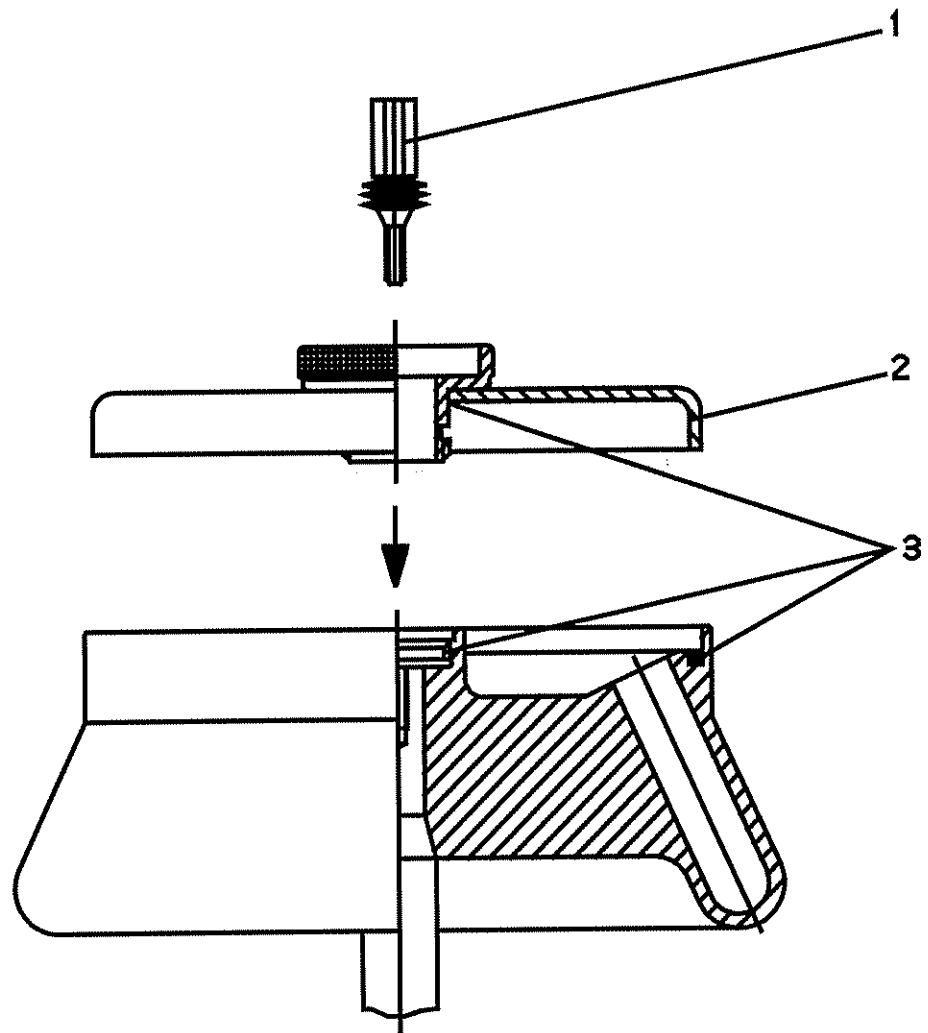

3. Installation, Start-up:

3.4 Initial Start-Up

Attention!

Before initial start-up please take care that your centrifuge is orderly installed (refer to chapter 3.2 "Installation").

3.4.1 Switching on of the Centrifuge

Press mains switch (on the right). When power is applied for the initial use, default values will be displayed:

- The displays (PD, ZD, DD) are illuminated.
- The speed display (DD) indicates "2000".
- The time display (ZD) indicates "2".
- The program panel (PD) indicates "-", ie.
 - the centrifuge is to accelerate to 2000 rpm with curve no. 9,
 - the centrifuge operation is terminated after 2 minutes,
 - deceleration of the centrifuge is carried out with curve no. 9,
 - no program number has been allocated so far.

3.4.2 Opening Lid

Press Lid-key (K5).

- The lid opens.
- The display shows the set values.

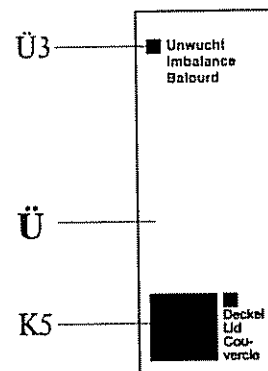

3.4.3 Insertion of Rotor

Put a rotor onto the shaft and fasten it by screwing the rotor tie-down screw onto the shaft. Please use the supplied rotor spanner (refer to chapter 3.3 "Insertion of rotor and accessories"). Please pay attention to the fact that during tightening the disc spring of the rotor tie-down screw is pressed together and the screw is tightened.

3. Installation, Start-up:

3.4.4 Selecting a Rotor or Bucket Number

Select LED "Rotor" (D3) by pressing the parameter key (DP) in the speed panel.

- LED "Rotor" (D3) is illuminated,
- a rotor part no. will appear on the speed display.

Pressing the Edit-key in the input panel activates the change mode (Edit-Aktiv-LED illuminated).

- Select the rotor number pressing the cursor keys until the correct number is displayed in the speed display,
- if a swing-out rotor with several available buckets had been selected, flashing rotor LED and display of "buc" in the time panel after pressing the Enter-key or parameter key request for input of bucket number,
- terminate input by pressing the Enter-key,
- with the new rotor or bucket number new set values may be displayed.

3.4.5 Starting and Stopping a Run

Close the lid.

- The LED's of the Start-key (K1) and the Short-key (K2) are illuminated, indicating that operation can be started.

Conditions

- Entries must be completed.
- No active faststop.

Press the Start-key (K1) (for optional methods please refer to chapter 4.3.1 "Key Short (K2)"),

- the LED of the Start-key (K1) will extinguish,
- the LED's of the Stop and Faststop-keys (K3, K4) are illuminated,
- the motor accelerates to the set speed with the preselected curve, LED K5 will extinguish,
- the speed display (DD) indicates the current rotor speed.

Stopping a run in progress

Press the Stop-key (K3),

- the Start-key LED is illuminated again, indicating that the operation can be restarted by pressing the Start-key,
- the motor decelerates according to the set deceleration curve until it comes to a standstill,
- the display continues to indicate the current operational data.

3. Installation, Start-up:

Or:

Press the Faststop-key (K4),

- the Start-key LED will not light up,
- operation cannot be continued by pressing the Start-key,
- the motor decelerates with maximum deceleration to a standstill,
- the display continues to indicate the current operational data.

For starting please open and close the lid.

The run is over,

- the time display (ZD) changes to "0",
- the Start-key LED is illuminated, indicating that operation can be restarted by pressing the Start-key,
- the motor decelerates with the set deceleration curve up to standstill,
- the display continues indicating the current operational data.

Press the Lid-key (K5),

- the lid opens,
- the set values of the selected program are displayed again.

Note!

In the event of problems please refer to chapter 8.5 "Error correction".

4.1 Operating Panel

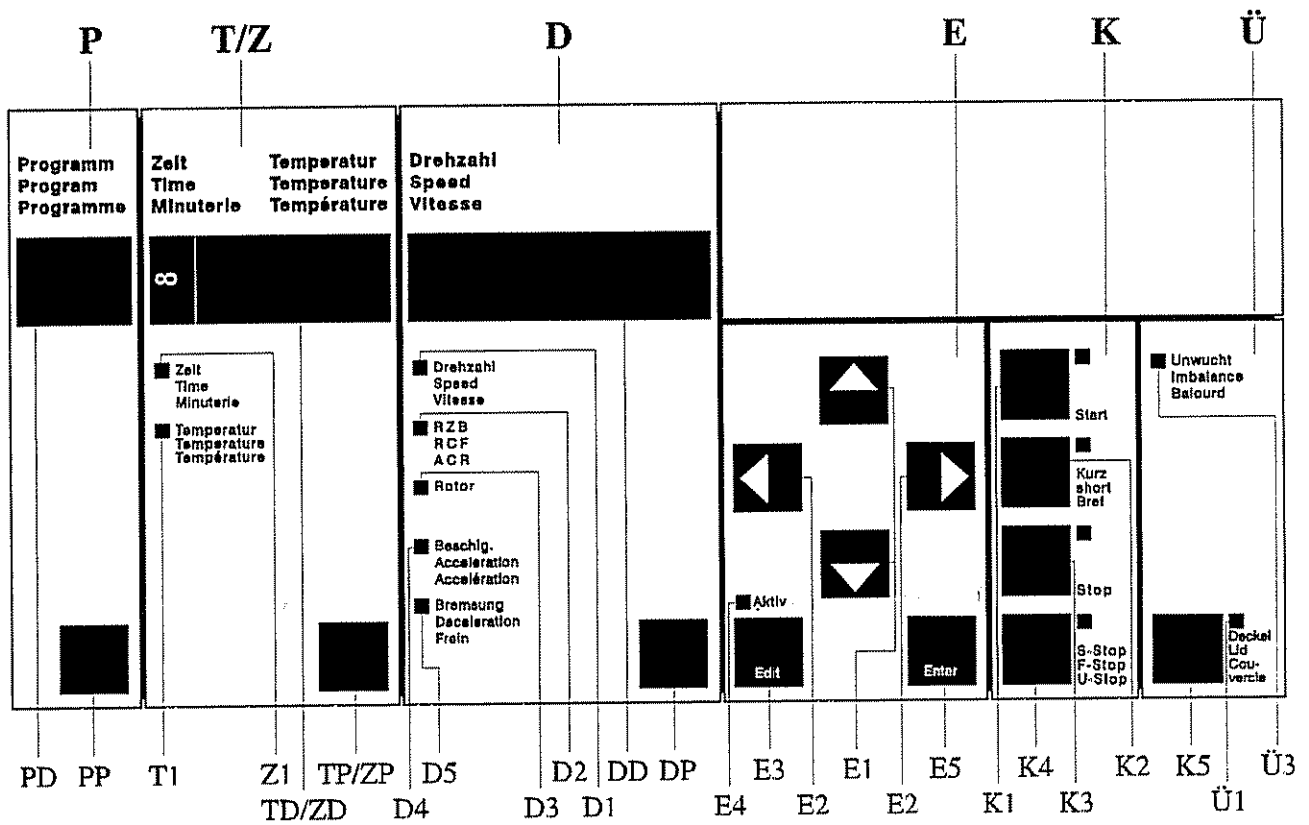

P	Program panel	E	Input panel
PP	Program parameter key	E1	Alteration keys
PD	Program panel display	E2	Cursor keys
		E3	Edit-key
Z	Time panel	E4	Edit-Aktiv-LED
ZP	Time parameter key	E5	Enter-key
Z1	Time-LED		
ZD	Time display	K	Command panel
		K1	Start-key
D	Speed panel	K2	Short-key
DD	Speed display	K3	Stop-key
DP	Speed parameter key	K4	Faststop-key
D1	Speed-LED		
D2	RCF-LED	Ü	Monitoring panel
D3	Rotor-LED	Ü3	Monitoring-LED imbalance
D4	Acceleration-LED	Ü1	Monitoring-LED lid
D5	Deceleration-LED	K5	Lid-key

In non-refrigerated centrifuges the temperature panel is inactive.

4. Operating Elements:

4.1 Operating Panel (Folding Illustration at the End of the Operating Manual)

All settings of the centrifuge are accessed via the operating panel. The operating panel is divided into display panels and control panels.

4.2 Displays and Keys

- Speed panel (D)
- Time panel (Z)
- Program panel (P)

The individual panels contain the following operator controls and displays:

Displays

(Displays are labelled by two letters, the latter one being a D: DD, ZD, PD). The displays are located at the upper part of the panel. Because of a high intensity contrast, they are easy to read and allow for a simultaneous presentation of important data of the centrifuge operation (eg. speed, time etc.).

Light Emitting Diodes (LED)

(The LEDs are labelled by the letter of the corresponding panel and numbered in sequential order: eg. D1, D2, ...). The LED's are arranged vertically below the displays. One of the LED's is constantly on. It identifies the selection in the corresponding display.

Parameter Keys

(The keys are labelled with two letters, the latter being a P: PP, ZP, DP). The parameter key is located at the bottom right corner of each panel. Pressing a parameter key of an active panel changes to the next parameter of this group. By pressing a parameter key of another panel the cursor changes to this panel. In the alteration mode the cursor is activated.

4. Operating Elements:

Input Keys

The input keys are divided in:

- Alteration keys
- Cursor keys
- Edit-key
- Enter-key



Alteration Keys

The alteration keys are labelled with ▲▼.

With these keys values can be increased ▲ or decreased ▼ by depressing the ▲ or the ▼ key.

Short pressing of the key results in one single counting step, holding the key in continuous steps with increasing speed. Counting terminates at the end of the respective value but can be continued by pressing the counting key again, resulting in an overflow.

Cursor Keys

The cursor keys are labelled with ◀▶.

The cursor position through the displays can be selected using the cursor keys. This is particularly advantageous, if extensive value alterations are necessary.

Edit-Key

The Edit-key is labelled with "Edit".

The Edit-key switches to the alteration mode (Edit-Aktiv-LED on).

The display changes from actual value display to set value display. After pressing the Edit-key again the alteration mode is terminated, possible changes of parameters are not saved.

Enter-Key

The Enter-key is labelled with "Enter".

With the Enter-key the parameter values are read and saved. They are also available after power off. The alteration mode finishes by pressing the Enter-key.

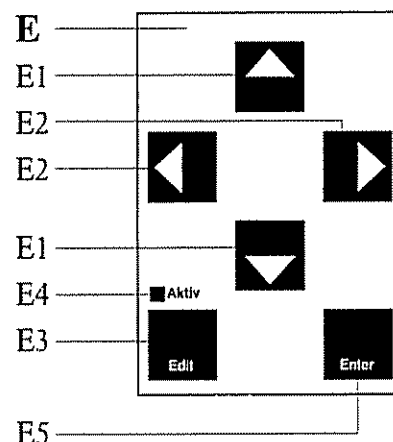

4. Operating Elements:

4.3 Command Panel (K)

The centrifuge operation is started via the command panel. Keys can be pressed when their LED is on.

Start-key (K1)

This key can be used for the following:

- starting centrifuge operation,
- terminating a previously started deceleration process and restarting centrifuge,
- shifting to short-run at preselected speed. Pressing Start-key continuously for the time of the short run leads to acceleration max. to the set speed **with the reselected acceleration curve** and after release deceleration **with the preselected deceleration curve**. Max. range 9 min 59 sec.

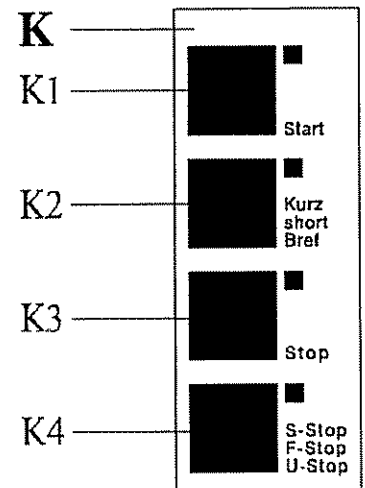

The centrifuge can be started when

- the lid is closed,
- no incorrect entries have been made,
- no LED`s are flashing (except rotor LED),
- the Start-LED is on,
- the Faststop-key has not been previously pressed,
- entries are finished.

Key Short (K2)

With this key the centrifuge can be accelerated to the max. speed of the rotor **with max. acceleration** and decelerated **with the max. deceleration curve** after releasing the key. Max. range 9 min. 59 sec.

Stop-key (K3)

This key can be used to terminate a run. The centrifuge decelerates according to the preset curve to a standstill. Deceleration can be terminated by pressing the Start-key again.

4. Operating Elements:

Faststop-key (K4)

Pressing this key decelerates the centrifuge as fast as possible. This deceleration process cannot be stopped, the centrifuge comes to a standstill in any case. Restarting is only possible after opening and closing the lid.

Lid-key (K5)

This key is used to open the lid. This can only be executed if

- the centrifuge has come to a standstill,
- the lid LED is on.

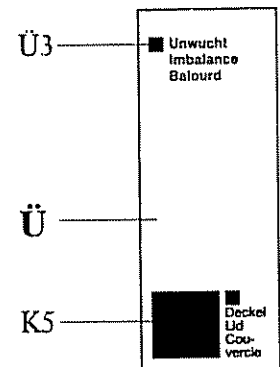

4. Operating Elements:

4.4 Display Panels

4.4.1 Speed Panel (D)

Speed (D1)

With entering a speed, the set value of the centrifuge speed is selected. After starting the centrifuge the current actual speed of the rotor is displayed.

RCF (D2)

The relative centrifugal force (abbrev. RCF) is an indication of the stress the sample is exposed to during a run. This value can be preset. The resulting speed is automatically calculated and displayed. After starting the run, the actual relative centrifugal force is displayed, if the RCF parameter is selected.

Rotors/Buckets (D3)

Rotor LED illuminated:

The desired rotor is selected via the alteration keys. All available rotors are offered for selection in the display in sequential order by pressing these keys. After selection of the desired rotor and display in the speed panel input is terminated by pressing the Enter-key. Pay attention to max. allowable speed.

After pressing the Enter-key or parameter key the Rotor-LED is flashing, if various buckets are available for the set rotor. After selection of the desired bucket and display in the speed panel input is terminated by pressing the Enter-key.

Attention: Please take care that the correct bucket part number is entered as otherwise the max. allowable speed could be exceeded. This is not allowed.

Acceleration (D4)

The acceleration number selects an acceleration curve which the centrifuge will follow. Two different versions are available:

- 0 - 9 linear
- 10 - 19 quadratic in a speed range up to 1 000 rpm

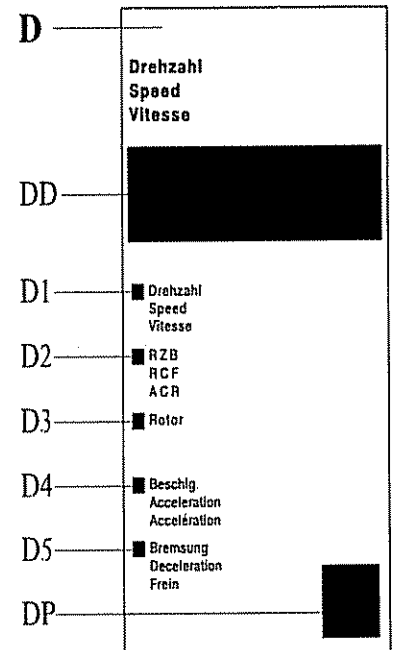

4. Operating Elements:

The curves 0 - 19 are preset by the manufacturer and cannot be changed by the user. Their shape is further explained in chapter 8.1 "Slope of the specified curves, linear curves" and 8.2 "Quadratic curves". Curves 0 - 9 are linear, curves 0 - 19 quadratic in the speed range up to 1 000 rpm. In the speed range exceeding 1 000 rpm. acceleration is linear.

The acceleration is expressed by the curve slope. For example: curve no. 8 is steeper than curve no. 7, ie. the centrifuge reaches its final speed within a shorter period.

Curves 9 and 19 apply a maximum acceleration to the centrifuge. These curves represent an exception. The centrifuge accelerates with its maximum torque. The time necessary to reach this maximum is only dependent on the inertia of the rotor.

Deceleration (D5)

The deceleration number selects a deceleration curve that decelerates the centrifuge down to standstill. The deceleration curves are inverted images of the acceleration curves and are labelled with identical numbers. Curve no. 0 represents brakeless deceleration.

4. Operating Elements:

4.4.2 Time Panel (Z)

Time (Z1)

(Temperature display inactive in non-refrigerated centrifuges.)

During standstill, this display shows the programmed time. During the operation of the centrifuge, the remaining run time is displayed in hours and minutes.

The time is entered in hours and minutes. Time is defined as the period from the start of the centrifuge to the beginning of deceleration, maximum value is 9 h 59 min.

If a run time of less than 1 or more than 9 h 59 min is selected, continuous operation is activated. The time display is omitted and the LED "∞" for continuous operation left of the display is illuminated. By entering a specific run time, the continuous mode is deactivated. By pressing the Enter-key the values are stored and the alteration mode is left.

During continuous operation, the time elapsed since the run start is displayed. The centrifuge operation can only be terminated by pressing the Stop- or Fast-stop-key.

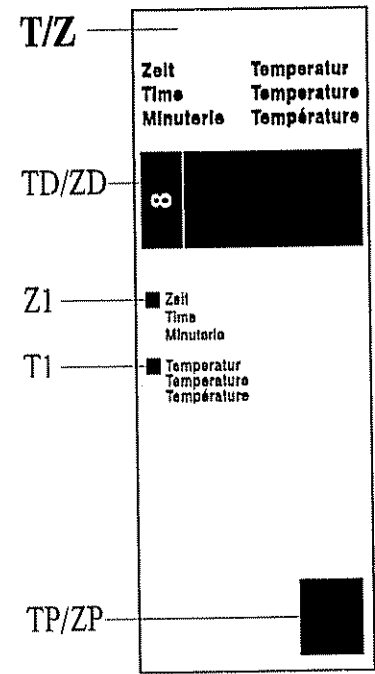

4. Operating Elements:

4.4.3 Program Panel (P)

Loading a program

After activation of the alteration mode by depressing the Edit-key the stored programs are available.

Select the program number using the alteration keys. Not allocated program numbers are indicated through "--" in the temperature, time and speed panel. The program "--" could be loaded at any time during standstill of the centrifuge. It contains the last changed parameters. The program is loaded by pressing the Edit-key again. The program used last is automatically loaded after restarting.

If a stored program should be loaded (eg. program no. 6), set desired program number and load the program by depressing the Edit-key.

10 programs no. 0 - 9 are available.

For further details please refer to chapter 5. "Programming".

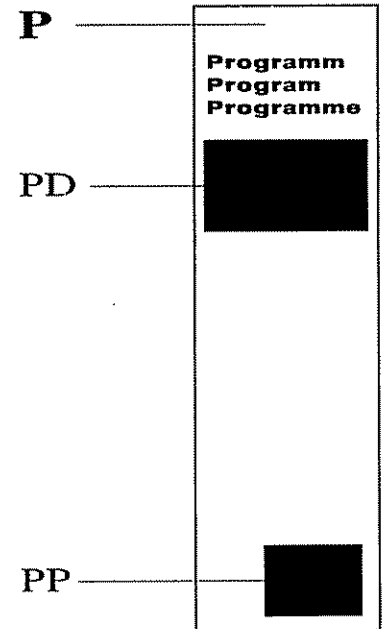

4. Operating Elements:

4.4.4 Monitoring Panel (Ü)

In this panel possible warning limits during operation are indicated by an illuminated or flashing monitoring and warning LED.

- "Imbalance" (Ü3)** - The imbalance LED has two control functions:
- Illuminated:** - Warning in the event of slight imbalance (warning limit < imbalance < cutoff limit). Run can be continued.
- Flashing:** - Run cannot be continued due to excessive imbalance (imbalance > cutoff limit). Run is terminated with max. deceleration.

Reason:

Improper loading or malfunction during operation (eg. glass breakage) resulting in an uneven run.

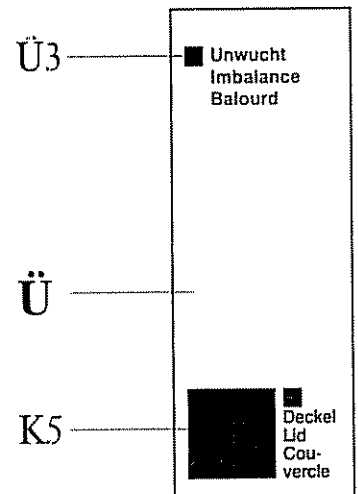

Note!

Additional information and a detailed description of errors and their correction is given in chapter 8.5 "Error correction".

5. Programming:

What is considered a program?

A program contains all data that are required and can be selected for the operation of the centrifuge.

In other words, a program contains a sequence of key operations in a memory. This sequence of key operations can be loaded easily to run the centrifuge with these values. A program is useful if a defined centrifuge operation should be repeated under same conditions.

A program saves time and helps to avoid entry errors which could often occur with repeated entries.

5. Programming:

5.1 Selection, Display and Alteration of Program Parameters

Set values

During standstill and with open cover, the centrifuge displays the last entered set values (PD, ZD, DD) in the program, time, and speed panels.

Actual Values

During the operation, the displays indicate the actual values.

The LED's (Z1, D1-5) below the displays indicate the parameters which the displays are currently showing. As a standard, the upper LED's are illuminated. The speed is displayed in the speed panel, the run time in the time panel and the program in the program panel.

The value of each of the parameters can be changed prior to a centrifuge operation by executing the following:

Press the Edit-key; the Edit-Aktiv-LED is illuminated. The third digit of the speed display is flashing.

You are in the alteration mode.

Select your parameter.

- This is executed by pressing the parameter key. The parameter values of the corresponding panel are displayed from top to bottom.
- The LED of the selected parameter illuminates.
- The digit of the display which should be changed is flashing, indicating that the user is still in the alteration mode.

Enter the new data via the alteration keys and save by pressing the Enter-key or recall existing data by renewed operation of the Edit-key.

5.2 Changing and Saving a Program

Each change of a parameter, eg. time, acceleration curve etc. is a program change. In the program display (PD) "-" is displayed instead of the program number. Saving of the parameters as a program is possible during standstill only.

1. Press the Edit-key.
2. Set cursor to program number:
 - Select desired program number using the alteration keys.
3. Press the Enter-key:
 - Saving the program, if no program was existing under the selected number.
 - Display of "quit" in the speed panel, if a program is already existing under the selected number with the following options:
 - Enter-key will overwrite the existing program.
 - Edit-key will terminate the storing process.

Note!

Invalid entries or such exceeding the allowed limits are not accepted (please refer to chapter 8.3 "Entry limitations").

5. Programming:

5.3 Changing a Program During Centrifuge Operation

When the centrifuge is running, the following parameters can be changed:

- Speed
- RCF
- Run time
- Switching to continuous operation mode/time mode
- Deceleration curve while the centrifuge does not decelerate
- Acceleration curve while the centrifuge does not accelerate

Select the parameter to be changed using the parameter keys (ZP, DP).

- The actual values are displayed.

Change the value using the alteration keys (please refer to chapter 5.2 "Selection, display and alteration of program parameters").

- The set values are displayed.

Press the Enter-key and then the Start-key.

- The actual values are displayed.

5.4 Programming the Relative Centrifugal Force

A change of these parameters automatically results in recalculation and change of other parameters, because there is a direct mathematical relation between them (please refer to chapter 8.4 "Mathematical relation").

Entry limits cannot be exceeded when using the alteration keys.

5.4.1 Specifying a Relative Centrifugal Force (RCF)

The relative centrifugal force, abbr. RCF, is a measure for the rotational force on the sample. Its magnitude depends on the radius and the speed (refer to chapter 8.4.1 "Relative centrifugal force (RCF)").

During the operation, the RCF value (actual value) is continuously calculated and can be displayed by calling the parameter. Therefore, a control over the actual force can be obtained.

During standstill, the RCF value (set value) is calculated when a speed or a rotor number is entered. The RCF can be preset. The resulting final speed is then calculated and displayed.

Example:

- Switch to the speed panel, activate RCF and enter the new RCF data (eg. a lower value than the one calculated from the final speed).
- Change to the speed panel.

The final speed has been recalculated.

5. Programming:

5.5 Special Time Preselection

5.5.1 Continuous Operation Mode

With activated continuous operation, the centrifuge run time is unlimited and must be manually stopped. The set values on the time panel are omitted, "∞" is illuminated.

The time elapsed since the run start is displayed.

Continuous operation mode can be activated when the centrifuge is running (refer to chapter 5.3 "Changing a program during centrifuge operation") or in standstill mode, if a run time of less than 1 or more than 9 hours and 59 minutes is selected. The run will continue until the Stop or Faststop-key is pressed.

Deactivating

By entering a concrete run time, continuous operation changes to timed run; the run time depends on the values entered.

5.5.2 Short-Time Operation

Two options of short-time operation are available:

Short: The centrifuge accelerates until release of the Short-key with the max. deceleration curve to the max. allowable speed of the set rotor and then it decelerates **with the max. deceleration curve**.

Short run: Pressing the Start-key longer than 1 second changes to short run. On the time panel the run time is displayed in seconds. The centrifuge accelerates until release of the Start-key with the selected curve to the set speed and then it decelerates **with the selected curve**.

The run times are displayed in minutes and seconds and increase until release of the Start-key or Short-key.

6. Notes for Centrifugation:

6.1 Practical Notes for Centrifugation

1. Locate centrifuge horizontally on a level surface.
2. Ensure safe location.
3. Keep at least 30 cm free space around the centrifuge.
4. Provide for sufficient ventilation.
5. Tighten rotor firmly onto motor shaft.
6. Avoid imbalance.
7. Load opposite buckets with same accessories.

8. Centrifugation with low capacity:
The vessels should be placed symmetrically so that the buckets and their suspensions are loaded evenly. Loading an inner or outer position of the bucket only is not allowed (see illustration). Even angle rotors should be loaded symmetrically to same weight.

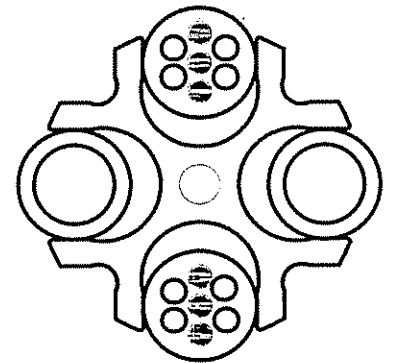

Centrifugation with different tubes:
Working with different tube sizes is possible. Opposite places must be loaded with the same vessels (see illustration).

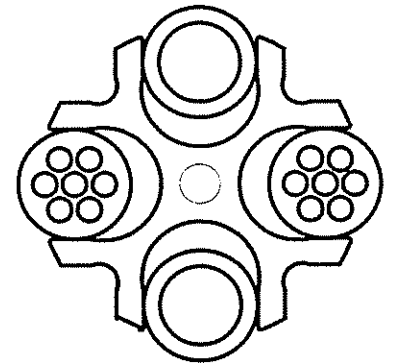

9. Load all positions of swing-out rotors.
10. Load vessels outside the centrifuge.
11. Please pay attention to the max. speed of glass tubes. At speeds over 4 000 rpm there is an increased breaking glass hazard.
12. Fill vessels carefully to same weight. Imbalances would result in increased wear of bearings.
13. Grease joints of buckets and rotor pins in swing-out rotors.
14. Use perfect accessories only.

6. Notes for Centrifugation:

15. Avoid corrosion to accessories by careful maintenance.
16. Spin infectious material in sealed rotors and buckets only.
17. Do not spin explosive or highly inflammable materials.
18. Record all program data, refer to form of appendix chapter 8.8.
19. When centrifuging substances with a density $> 1,2 \text{ g/cm}^3$ the allowable max. speed must be reduced (refer to chapter 8.4.2 "Density").

6. Notes for Centrifugation:

6.2 Forbidden Centrifuging Operations

1. Operation of not carefully installed centrifuge.
2. Operation without front or back panels.
3. Operation by non authorized personnel.
4. Operation with rotor not installed properly (refer to chapter 3.3).
5. Operation with incompletely loaded swing-out rotor or angle rotor with interchangeable buckets.

A rotor must always be loaded completely, empty places are not allowed!
Opposite buckets or carriers may nevertheless be empty. Mixed loading is allowed, if opposite places are loaded with same buckets and carriers of same weight.

6. Operation with overloaded rotors.

The load for a rotor is limited by its design and the max. speed (see rotor/bucket engraving) and must not be exceeded. The rotors are intended for liquids of max. homogeneous density of 1.2 g/cm³ if centrifuged at max. speed. If liquids of higher density are used, the speed must be reduced accordingly (refer to chapter 8.4 "Mathematical relation").

7. Operation with rotors, buckets and carriers showing corrosion or other defects.
8. Operation of very corrosive substances which can cause damages to material and effect mechanical strength of rotors, buckets and carriers.
9. Operation of rotors and accessories not allowed by the manufacturer, except commercial vessels of glass or synthetic materials. The use of poor commodity goods is not recommended. At high speeds breaking glass or bursting vessels can cause dangerous imbalances.
10. Operation in hazardous locations.
11. Operation with vessels of improper size.
12. Centrifugation of improper material.
13. Operation with partially filled plastic tubes in high-speed angle rotors.
14. Lifting or moving of the centrifuge during operation. Leaning against or resting on the centrifuge is not allowed.

6. Notes for Centrifugation:

15. Do not place potential dangerous material - eg. glass vessels containing liquids - near the centrifuge.
16. Attention: Do not open cover and/or reach into rotor chamber unless the rotor is at standstill. Never attempt to override the lid interlock system while the rotor is spinning.
17. Do not spin substances which could react upon the supply of high energy during centrifugation.
18. Do not spin explosive or highly inflammable materials.
19. Substances which could damage the material of the centrifuge, the rotors or the buckets anyhow must not be centrifuged or only under consideration of special safety measures. Infectious, toxic, pathogene or radioactive substances must be centrifuged in suitable rotors and vessels only.

7. Care and Maintenance:

7.1 Care and Cleaning of Centrifuge

Please use soap water or other water-soluble, mild agents for cleaning. Avoid corroding and aggressive substances. Do not use alkaline solutions or solvents or agents with abrasive particles. Before using detergents or decontamination agents which had not been recommended by us, the user has to contact us to make sure that such procedure would not damage the centrifuge.

Remove product particles from the rotor chamber using a cloth or paper towel. It is recommended to open the cover when the centrifuge is not in use so that moisture can evaporate. Increased wear of the motor bearings will thus be avoided. **If there is the risk of toxic, radioactive or pathogene contamination, special safety measures must be kept.**

7.2 Care and Cleaning of Accessories

For care of accessories special safety measures must be considered as these are measures ensuring operational safety at the same time.

Buckets, trunnions and also synthetic buckets are produced exactly in order to withstand the permanent high stress with high gravitational fields.

Chemical reactions as well as stress-corrosion (combination of changing pressure and chemical reaction) can effect or destroy the metals. Hardly detectable cracks on the surface expand and weaken the material without visible signs. When detecting a visible damage of the surface, a crack, a mark or any other change, also corrosion, the part (rotor, bucket etc.) must be replaced immediately.

In order to avoid corrosion, rotor incl. tie-down screw and cover seal, buckets and carriers must be cleaned and greased regularly with the supplied slushing oil (part no.: 70104 for 20 ml slushing oil). Before using detergents or decontamination agents which had not been recommended by us, the user has to contact us to make sure that such procedure would not damage the centrifuge. The rotor tie-down screw must be greased using the supplied grease (part no.: 70284).

Cleaning of accessories should be carried out external to the centrifuge once a week or preferably after every use. The rubber cushions should be removed from buckets and carriers. After this the parts should be dried with a soft cloth or also in a drying chamber at approx. 50 °C. **If there is the risk of toxic, radioactive or pathogene contamination, special safety measures must be kept.**

Especially aluminium parts are extremely corrosive. A neutral cleaning agent with a pH-value between 6 and 8 should be used for such parts. Alkaline agents exceeding pH 8 must be avoided. Especially aluminium parts must be greased regularly with slushing oil. This procedure essentially increases life time and reduces corrosion.

7. Care and Maintenance:

Careful maintenance increases life time and avoids premature failure of the rotor. Corrosion or resultant damages which are caused by insufficient care do not constitute a warranty claim.

7.3 Rotor Pins

The trunnion pins of the rotor should always be greased as only this ensures evenly swinging of buckets and thus quiet run of the centrifuge (part no. 70284 Grease).

7.4 Glass Breakage

In case of glass breakage all glass particles must be carefully removed. Rubber inserts have to be cleaned carefully and possibly be replaced. If a problem has occurred, the following has to be considered:

Glass particles in the rubber cushion will cause glass breakage again.

Particles on the rotor pins prevent buckets and carriers from swinging evenly which will cause an imbalance.

Glass particles in the centrifuge chamber will cause metal abrasion due to the strong air circulation. This dust will not only pollute the centrifuge chamber, the rotor, the buckets, the carriers and the material to be centrifuged but also damage the surfaces of the accessories, the rotors and the centrifuge chamber.

In order to totally remove the glass particles and the metal dust from the rotor chamber, it is advisable to grease the upper part of the centrifuge chamber with eg. Vaseline. Then the rotor should rotate for some minutes at a moderate speed. The glass and metal particles will now collect at the greased part and can easily be removed with a cloth together with the grease. If necessary repeat this procedure.

7.5 Sterilization and Disinfection of Rotor Chamber and Accessories

All usual disinfectants like eg. Sagrotan, Buraton or Terralin (to obtain at chemist's shops) can be used. The centrifuges and the accessories consist of different materials. A possible incompatibility must be considered. Before using detergents or decontamination agents which had not been recommended by us, the user has to contact us to make sure that such procedure would not damage the centrifuge. For sterilization by steam resistance to temperature of the individual material must be checked (refer to point 7.5.1 "Autoclaving"). Please contact your laboratory safety officer regarding proper methods to use. **If dangerous materials are used, the centrifuge and the accessories must be disinfected.**

7. Care and Maintenance:

7.5.1 Autoclaving

The life of the accessories essentially depends on the frequency of autoclaving and use. When the parts are showing changes in colour or structure or in the event of leaks etc., the accessories have to be replaced.

During autoclaving the caps of the tubes must not be screwed on to avoid deformation of the tubes.

Autoclaving:

Accessories	max. temp. °C	max. time min	min. time min	max. cycles
Glass tubes	134-138	5	3	-
Polycarbonate tubes	115-118	40	30	20
Polypropylene tubes	115-118	40	30	30
Teflon tubes	126-129	15	10	-
Aluminium rotors	126-129	15	10	-
Polypropylene rotor 12034	115-118	40	30	20
Polypropylene rotor 12124	115-118	40	30	20
Polycarbonate/Polyallomer lids for angle rotors	115-118	40	30	20
Aluminium buckets	126-129	15	10	-
Polycarbonate caps for buckets	115-118	40	30	50
Polypropylene caps for buckets	115-118	40	30	50
Rubber adapters	115-118	40	30	-
Rubber cushions	115-118	40	30	-
Round carriers for 13104/ 13117, Polypropylene	115-118	40	30	-
ditto, Polyallomer and Polycarbonate	115-118	40	30	-
Round carriers for 13350/ 13550, Polypropylene	115-118	40	30	-
Rectangular carriers, Polypropylene	115-118	40	30	-
ditto, Polyallomer and Polycarbonate	115-118	40	30	-

7. Care and Maintenance:

7.6 Checks by Operator

The operator has to pay attention that important parts of the centrifuge necessary for safety are not damaged.

This especially refers to:

1. Motor suspension
2. Concentricity of the motor shaft
3. Fastening of the trunnions in the rotor
4. Accessories, especially changes of structure like corrosion, cracks, material abrasion etc.
5. Screw connections

Furthermore, the earth wire must be checked regularly.

8. Appendix:

8.1 Slope of Specified Curves, Linear Curves

- The slope of a specified acceleration curve is defined as the time required to accelerate the rotor to 1000 rpm.
- With linear and quadratic slopes, curves are numbered in the direction of increasing acceleration (from right to left).
- The deceleration curves are inverted images of the acceleration curves with the same numbers (exception: curve 0).
- Curve 0 decelerates brakeless.

Comment: The acceleration time depends on the moment of inertia of the rotor.

Linear Curves (0 - 9)

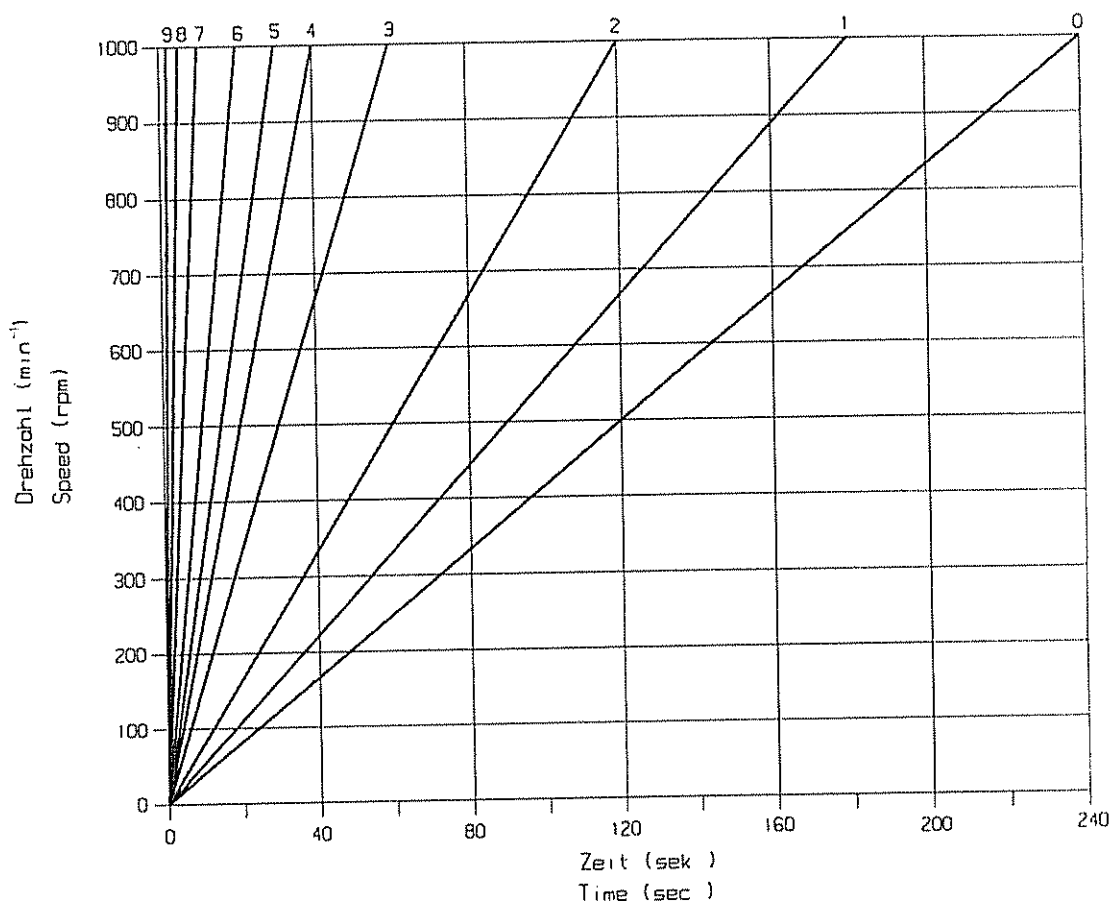

Figure 2

8. Appendix:

The curve 9 is a special case compared with the other curves. The centrifuge accelerates with max. torque. The acceleration time only depends on the moment of inertia of the rotor.

Linear curve no.	Slope
0	240 sec./1000 rpm.
1	180 sec./1000 rpm.
2	120 sec./1000 rpm.
3	60 sec./1000 rpm.
4	40 sec./1000 rpm.
5	30 sec./1000 rpm.
6	20 sec./1000 rpm.
7	10 sec./1000 rpm.
8	5 sec./1000 rpm.
9	0,9 sec./1000 rpm.

8.2 Quadratic Curves

- The deceleration curves are inverted images of the acceleration curves with the same numbers.

Quadratic Curves (10 - 19)

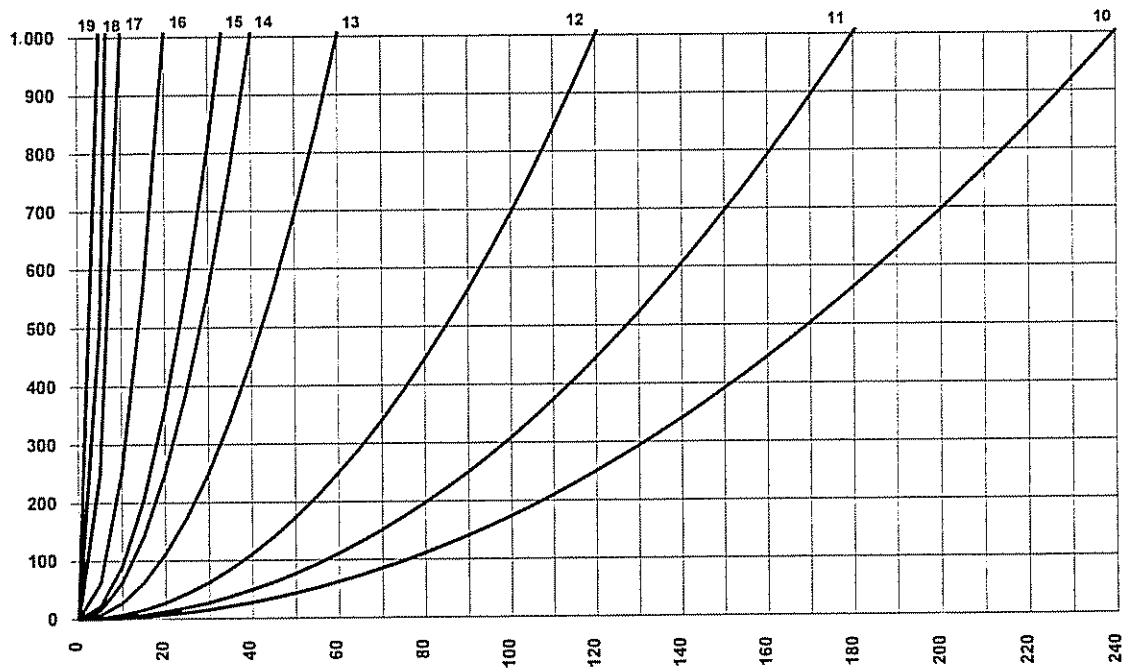

Figure 3

The curve 19 is a special case compared with the other curves. The centrifuge accelerates with maximum torque. The acceleration time only depends on the moment of inertia of the rotor.

8. Appendix:

Quadratic curve no.	Time up to 1000 rpm	Slope from 1000 rpm linear
10	240	120 sec./1000 rpm.
11	180	90 sec./1000 rpm.
12	120	60 sec./1000 rpm.
13	60	30 sec./1000 rpm.
14	40	20 sec./1000 rpm.
15	30	15 sec./1000 rpm.
16	20	10 sec./1000 rpm.
17	10	5 sec./1000 rpm.
18	5	2,5 sec./1000 rpm.
19	0,9	0,5 sec./1000 rpm.

8.3 Entry Limitations

Valid entries or area limits could depend on:

- Type of centrifuge
- Rotor
- interdependent parameters

All entry limits are automatically checked. When reaching a limit the counting operation is stopped. By pressing the corresponding alteration key again delimiting to the max. or min. value is executed when the limits are exceeded or fallen below for the first time, with the next underflow the maximal and with overflow the minimal value is displayed.

Interdependent parameters are limited further with a change of the corresponding parameter. When using the alteration keys, limit errors are impossible. With the alteration of a parameter, the corresponding parameter is recalculated. The recalculated parameter is indicated by a flashing parameter-LED. If the changed parameter is selected, the recalculated value is displayed.

8.4 Mathematical Relation

8.4.1 Relative Centrifugal Force (RCF)

The parameters speed, RCF and the diameter of the rotor are interrelated via the following formula:

$$\text{RCF} = 11,18 * 10^{-6} * r * n^2$$

If two values are given, the third value is determined by the equation. If the speed or the rotation radius are changed, the resulting RCF will be recalculated. If the RCF is altered, the speed under consideration of the radius is adapted accordingly.

r = radius in cm

n = speed in rpm

RCF without dimension

8.4.2 Density

If the density of the liquid is higher than 1.2 g/cm³, the allowed maximum speed of the centrifuge is calculated according to the following formula:

$$n = n_{\text{max}} * \sqrt{(1 / \text{Gamma})}$$

Gamma = density in g/cm³

8.5 Error Correction

Most of the errors can be reset by power off/on. In the event of a short power supply failure during a run, this run is interrupted and can be continued by pressing the Start-key.

No indication on the display: Actions:

- | | |
|---|---|
| <ul style="list-style-type: none">- No voltage in the socket?- Power cord plugged in and line voltage present?- Input fuse ok?- Power switch on? | <ul style="list-style-type: none">• Check fuse in mains supply.• Plug in power cord correctly.• Replace input fuse (see nameplate for rating).• Switch on power. |
|---|---|

8.5.1 Centrifuge cannot be Started

a) Start-key LED not illuminated:

- | | |
|---|--|
| <ul style="list-style-type: none">- Edit-Aktiv-LED illuminated.- Lid-LED (Ü1) not illuminated. | <ul style="list-style-type: none">• Edit-Active-Mode is left by pressing the Enter-key or the Edit-key.• Close lid. Lid locks must close. |
|---|--|

- b) Start-key LED illuminated: • Power off/on. If error occurs again, call service.

8.5.2 Centrifuge Decelerates during Operation

a) Imbalance-LED (Ü3) flashing:

- | | |
|--|--|
| <ul style="list-style-type: none">- Rotor is loaded unevenly.- Centrifuge tilted.- Drive error (mechanical damage).- Centrifuge was moved during operation.- Centrifuge displays an error 73 to 75 after power on. | <ul style="list-style-type: none">• Balance loading.• Align centrifuge.• Call Service.• Restart after opening and closing lid.• These error numbers indicate an error in the internal program storage. This error is eg. generated when a power failure occurs during a storage procedure. |
|--|--|

8. Appendix:

8.5.3 Lid cannot be Opened/Closed

When first trying to open the lid the lock is not released. Press the lid down with both hands until the yellow LED at the key K5 is illuminated.

8.5.4 Emergency Lid Release

In the event of a power supply failure it is possible to manually open the lid.

At the upper left panel there is a stopper which can be removed eg. with a screw driver. The lid can be released by pulling the visible string.

Attention!

The lid may only be unlocked and opened when the rotor is at standstill.

8. Appendix:

8.6 Error Codes

Error no.	Kind of error	Measures	Comment
1-62	Internal error	<ul style="list-style-type: none">• let slow down• power off/on	
69-77	EEPROM error	<ul style="list-style-type: none">• let slow down• power off/on	ATTENTION: Saved curves and programs could have been deleted.
78	Lid does not close	<ul style="list-style-type: none">• power off/on• remove foreign matter	
79	Faulty log identification	<ul style="list-style-type: none">• press lid key• close lid rapidly• check log opening for impurities	
80	Lid electronics defective	<ul style="list-style-type: none">• contact Service	
81	Rotor spins with open cover	<ul style="list-style-type: none">• let slow down• close lid• power off/on	
82-83	Lid does not open	<ul style="list-style-type: none">• power off• emergency lid release	
84	Excess temperature heat sink	<ul style="list-style-type: none">• let cool down• provide for better ventilation• power off/on	
85	Excess temperature centrifuge chamber (> 50 °C)	<ul style="list-style-type: none">• let cool down• provide for better ventilation• power off/on	
87	Actual temperature > 45 °C resp. < -20 °C	<ul style="list-style-type: none">• provide for better ventilation	
88	Excess temperature switch activated (temp. > 70 °C)	<ul style="list-style-type: none">• provide for better ventilation• refrigerating machine defective	
90-96	Sensor defective	<ul style="list-style-type: none">• power off/on	
98	Faulty rotor identification	<ul style="list-style-type: none">• check rotor	
99	Incorrect rotor	<ul style="list-style-type: none">• check rotor and set rotor resp. bucket identification	

Should it not be possible to repair the failure, please contact Service.

8.7 Speed-RCF-Diagram

An additional help is the enclosed Speed-RCF-Diagram.

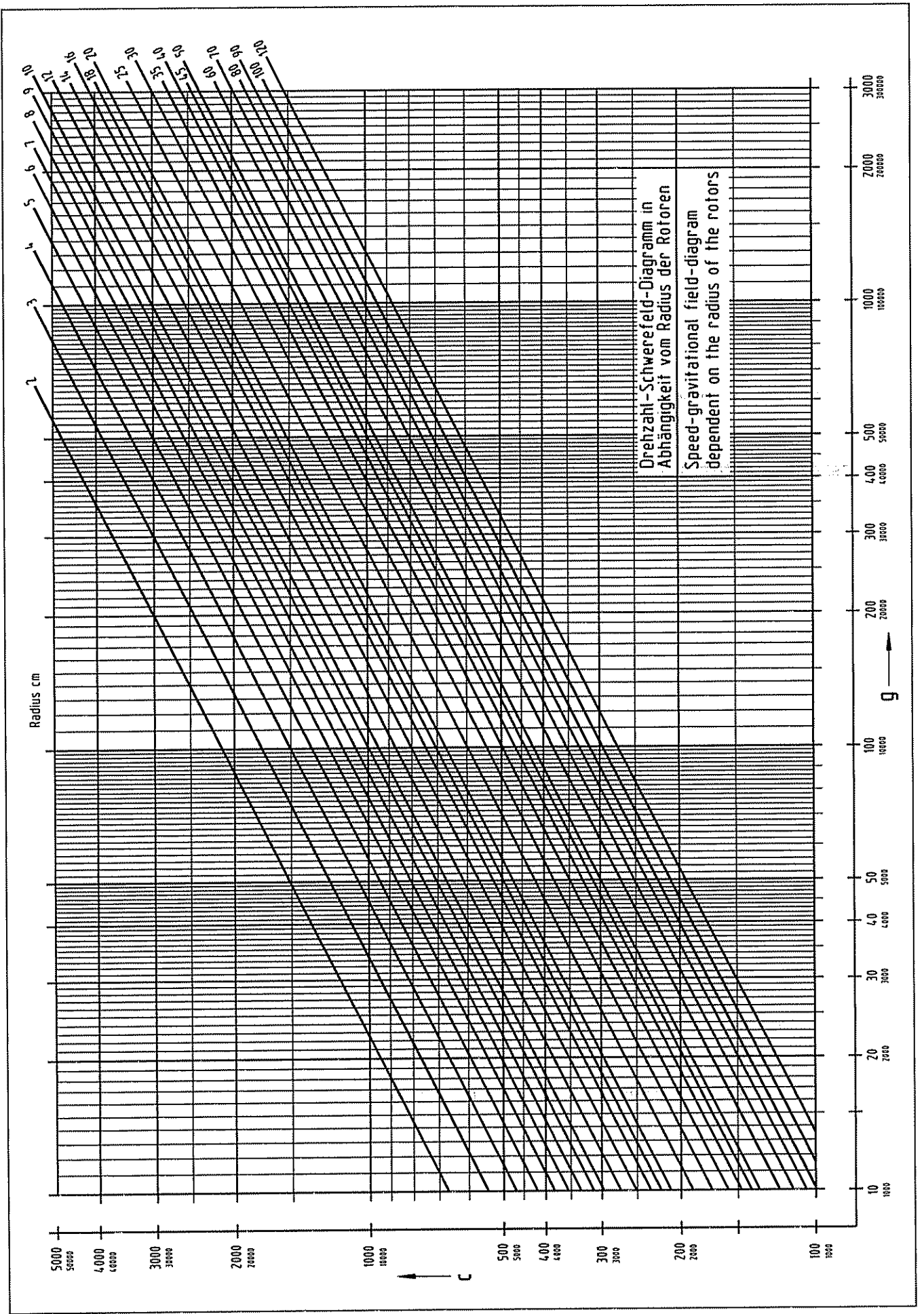

8. Appendix:

8.8 Declaration of Decontamination / Return Declaration

The following declarations serve for keeping safety and health of our employees. Fill in the forms and attach them when returning centrifuges, accessories and spare parts. Please understand that we cannot carry out any work before we have the declarations. (We recommend to make **several copies of this page.**)

8. Appendix:

✂-----

!!! Attention – This form must be glued on outside of the box !!!

Return declaration

	YES	NO
Decontamination declaration inside :		
Unit / component contaminated :		
Unit / component unused (new) :		

!!! Attention – This form must be glued on outside of the box !!!

✂-----

Please make some copies before removing this page.

8. Appendix:

✂-----

Declaration of Decontamination of Centrifuges, Accessories and Spare Parts

This declaration may only be filled in and signed by authorised staff.

Repair Order dtd. : _____
Order No. : _____
Type of unit : _____ Serial No. : _____
Type of unit : _____ Serial No. : _____
Type of unit : _____ Serial No. : _____
Type of unit : _____ Serial No. : _____
Accessories : _____

Is the equipment free from harmful substances ? YES NO

If not, which substances have come into contact with the equipment?

Name of the substances : _____

Remarks (e.g. to be touched with gloves only) ; _____

General characteristics of the substances :

Corrosive	<input type="radio"/>	Explosive	<input type="radio"/>
Biologically hazardous	<input type="radio"/>	Radioactive	<input type="radio"/>
Toxic	<input type="radio"/>		

In combination with which substances may hazardous mixtures develop?

Name of the substances : _____

Has the equipment been cleaned before shipment? YES NO

Is the equipment decontaminated and not harmful to health? YES NO

Prior to repair, radioactively contaminated components must be decontaminated according to the valid regulations for radiation protection.

Legally Binding Declaration

I / we hereby declare that the information on this declaration are correct and complete.

Company / Institute : _____
Street : _____
Postcode, City : _____
Tel. : _____ FAX : _____
Name : _____

Date : _____ Stamp : _____

Signature : _____

✂-----

Please make some copies before removing this page.

Program Data:

8.9 Program No.:

Used for

.....
.....
.....
.....

Alteration:

.....
.....

by:

.....

Date:

.....

Speed

.....

Gravitational field

.....

Rotor

.....

Bucket

.....

Made on:

.....

by:

.....