

Refrigerated Centrifuge

3 K 18

OPERATING MANUAL

Dear customer,

Congratulations for purchasing a SIGMA laboratory centrifuge. You have selected a device which combines many advantages.

A wide spectrum of programming options and an electronic operation control allow a trouble-free use of the centrifuge. With its 3-phase drive, maintenance-free quiet operation without any carbon dust pollution is guaranteed.

Your device is equipped with user-friendly options which make the operation and standard settings easier for you. Built-in error-detecting functions keep the user from entering incorrect values and check the complete operation.

A special advantage is the storage capacity the centrifuge offers. The instrument has a large program memory which can store up to 60 different data sets and is also capable of keeping the last run program in its memory for an unlimited amount of time allowing the program to be restarted at any time - even if the centrifuge was turned off in between.

All settings are executed via the control panel the coated surface of which offers a clear arrangement and protects the device against moisture and dust at the same time. In addition, the interior of the centrifuge is also easy to clean. With that we are able to offer you a device that combines functional variety with practical applications.

We thank you for your confidence and wish you a successful application of the centrifuge.

SIGMA Laborzentrifugen GmbH
Postfach 1713 - D-37507 Osterode
Tel. 05522/5007-0 - Telefax 05522/500712
Telex 9 65 101

EU Statement of Conformity

**in accordance with the EU Machine Directive 89/392/EEG, Appendix II A
and the EU EMV-Directive 89/336/EEG**

**We, Sigma Laborzentrifugen GmbH
An der Unteren Söse 50
D-37520 Osterode am Harz**

**hereby declare that the following machine is in accordance with the relevant standard
Safety and Health Regulations of the EU Directive due to its conception and design. In
the event of an alteration which had not been agreed by the manufacturer this declara-
tion will be invalid.**

Machine: Laboratory Centrifuge

Type: 3K 18

Machine No.: 10718, 10719, 10721, 10722

**Relevant EU Directives: EU Machine Directive (89/392/EEG)
EU Low Voltage Directive (73/23/EEG)
EU-EMV Directive (89/336/EEG)**

**Applied harmonized standards particularly: EN 292-1, EN 292-2
EN 954-1
61010-2-20
EN 50081-1, EN 55011, EN 55014
EN 50082-1**

**Applied national standards and technical specifications particularly: DIN 349
VBG 4, VBG 7z, VBG 20**

Date/Manufacturer's Signature: 08.01.1998,

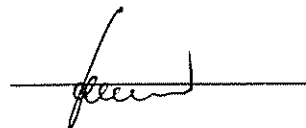

Position:

Managing Director

Filing:

.....
Serial No.

SHORT INSTRUCTION

for SIGMA 2K 15, 3K 15, 3K 18, 4K 15

with free programming of the operation parameters

Important: Please pay attention to the notes in the detailed operating instructions

1. _____
Remove transport safety device if present (3.1.1).

2. _____
Check the name rating plate for the correct voltage and frequency, then plug the power cord into the wall receptacle (3.2).

3. _____
Press the power switch to on (3.4.1) (on rear panel) Close the lid.

4. _____
Turn key-operated switch in the mode display until LED **Univers.** is illuminated (4.3.2).
The following displays are illuminated (basic program, if no program had been stored):

- Speed panel **2000** LED **Speed**
- Time panel **2.00** **m ss** LED **Time**
- Program panel -- LED **Program**
- Temperature panel **20** LED **Temperature**
- LED Lid
- LED **Start**
- LED **Short**

The run can be started with these parameters, if the rotor is installed and the lid is closed.

4.1 _____
Open the lid, install the rotor according to detailed operating instructions (3.4.2 and 3.4.3) and close the lid.

5. _____
Enter run parameters (3.4 and 4.2).

Press the Edit-key,

LED Aktiv is illuminated (4.2).

a) Press the parameter key in the speed panel until LED **Rotor** is illuminated (3.4.4).
Select the rotor number using the alteration keys $\Delta\nabla$.
The rotor number is displayed in the speed panel.

If "buc" is displayed in the time display and LED **Rotor** is flashing, enter bucket number.

- b) Press the parameter key in the speed panel until LED **Speed** is illuminated.
The desired speed can be set using the alteration keys $\Delta\nabla$.
The corresponding relative centrifugal field RCF is calculated from rotor number and speed.
- c) Press the parameter key in the speed panel until LED **RCF** is illuminated.
The relative centrifugal field of the rotor in use at the set speed is displayed.
Another centrifugal field can be set using the alteration keys $\Delta\nabla$.
The corresponding speed is calculated.
- d) Press the parameter key in the speed panel until LED **Density** is illuminated.
Set higher specific gravity of the product. The max. allowed speed is automatically reduced.
- e) Press the parameter key in the time panel until LED **Time** is illuminated, the last digit will flash.
Set the desired run time using the alteration keys $\Delta\nabla$. The run time is displayed depending on the set units in minutes/seconds, hours/minutes or days/hours (4.4.2 Time).
- f) Press the parameter key in the temperature panel until LED **Temperature** is illuminated.
Set the desired temperature in °C using the alteration keys $\Delta\nabla$.
If a temperature below 0 °C is desired, press the alteration key until the temperature below 0 °C is displayed with "-".
- g) Press the parameter key in the temperature panel until LED **Excess temperature K** is illuminated.
Set desired value.

- h) Press the parameter key in the program panel until LED **Acceleration** is illuminated. Select the desired acceleration curve using the alteration keys $\Delta\nabla$ (0 - 19 available).
- i) Press the parameter key in the program panel until LED **Deceleration** is illuminated. Select the desired deceleration curve using the alteration keys $\Delta\nabla$ (0 - 19 available).
- j) Press the parameter key in the program panel until LED **Program** is illuminated. Select desired program number using the alteration keys $\Delta\nabla$ (0 - 59 available.)

Store entered data using the Enter-key.

6. _____
Start the program using the Start-key.

7. _____
Alteration of program (during run; 5.6):

- a) Press the Edit-key.
- b) Select required panel using the parameter key. The parameter to be changed will flash.
- c) Change the value using the alteration keys $\Delta\nabla$.
- d) The changed parameters are used for the actual run by pressing the Enter-key.

8. _____
The run can be stopped at any time by pressing the Stop or Faststop-key.

Control Panel

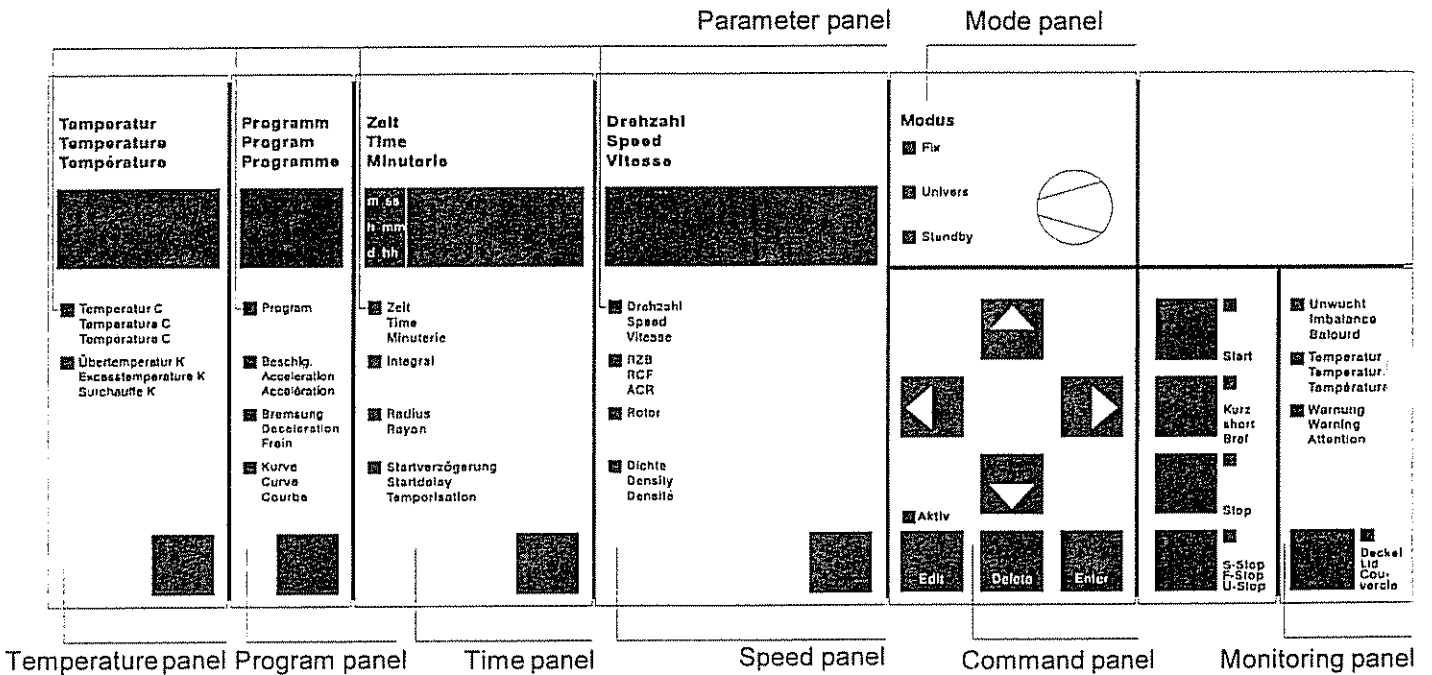

(Subject to technical alterations)

Table of Contents:

1. General Information

- 1.1 Technical data
- 1.2 Suitable accessories
- 1.3 Scope of supply
- 1.4 Standards and regulations
- 1.5 Safety instructions

2. Description of the Centrifuge

- 2.1 General outlay
- 2.2 Construction and constructive safety measures
- 2.3 Drive
- 2.4 Data input and output
- 2.5 Electronics
- 2.6 Safety devices
 - 2.6.1 Lid lock, cover closing device
 - 2.6.2 Imbalance monitoring system
 - 2.6.3 Excess temperature in the centrifuge chamber
 - 2.6.4 Rotor monitoring
 - 2.6.5 Standstill monitoring
 - 2.6.6 System check
 - 2.6.7 Earth wire check

3. Installation and Start-up

- 3.1 Unpacking of the centrifuge
 - 3.1.1 Transport safety device/transport conditions
- 3.2 Installation
 - 3.2.1 Site
 - 3.2.2 Connection
 - 3.2.3 Fuses on site
 - 3.2.4 Bench top fastening
- 3.3 Insertion of rotors and accessories
 - 3.3.1 Fastening of angle rotors with hermetically sealed lid
- 3.4 Initial start-up
 - 3.4.1 Switching on of the centrifuge
 - 3.4.2 Opening lid
 - 3.4.3 Insertion of rotor
 - 3.4.4 Selecting a rotor or bucket number
 - 3.4.5 Starting and stopping a run

Table of Contents:

4. Operating Elements

- 4.1 Operating panel
- 4.2 Displays and keys
- 4.3 Control panels
 - 4.3.1 Command panel (K)
 - 4.3.2 Key-operated switch (S)
- 4.4 Display panels
 - 4.4.1 Speed panel (D)
 - 4.4.2 Time panel (Z)
 - 4.4.3 Temperature panel (T)
 - 4.4.4 Program panel (P)
 - 4.4.5 Monitoring panel (U)

5. Programming

- 5.1 Selection, display and alteration of program parameters
- 5.2 Loading a program (calling up a saved program)
- 5.3 Changing and saving a program
- 5.4 Deleting a program
- 5.5 Changing a program during centrifuge operation
- 5.6 Programming the relative centrifugal force, density and integral
 - 5.6.1 Specifying a relative centrifugal force (RCF)
 - 5.6.2 Specifying a density
 - 5.6.3 Specifying an integral
- 5.7 Programming variable acceleration and deceleration curves
 - 5.7.1 Deleting intervals
 - 5.7.2 Changing a programmed curve
 - 5.7.3 Example: Specifying a program with a freely programmable curve
- 5.8 Pre-cooling

6. Notes for Centrifugation

- 6.1 Practical notes for centrifugation
- 6.2 Forbidden centrifuging operations

7. Care and Maintenance

- 7.1 Care and cleaning of centrifuge
- 7.2 Care and cleaning of accessories
- 7.3 Rotor pins
- 7.4 Glass breakage
- 7.5 Care and cleaning of the condenser
- 7.6 Sterilization and disinfection of rotor chamber and accessories
- 7.7 Checks by operator

Table of Contents:

8. Appendix

8.1	Slope of the specified curves, linear curves
8.2	Quadratic curves
8.3	Entry limitations
8.4	Mathematical relation
8.4.1	Relative Centrifugal Force (RCF)
8.4.2	Density
8.4.3	Integral
8.5	Error correction
8.5.1	Centrifuge cannot be started
8.5.2	Centrifuge decelerates during operation
8.5.3	Lid cannot be opened/closed
8.5.4	Emergency lid release
8.6	Error codes
8.7	Diagram speed/gravitational field
8.8	Form program data
8.9	Form curve data
8.10	Leaflet

1. General Information:

1.1 Technical Data	
Manufacturer:	S I G M A Laborzentrifugen GmbH 37520 Osterode
Type:	3K 18
Electr. connection:	230 V, 50/60 Hz
Power consumption (kVA):	1,15
Rated power (kW):	0,98
Max. current consumption (A):	5,5
Power data:	
Max. speed (rpm):	18 000
Max. capacity (l):	0,8
Max. gravitational field(x g):	29 703
Max. kin. energy (Nm):	18 900
Further parameters	
Time range:	9 min, 59 sec 9 h, 59 min 9 days, 23 h
Temperature setting range:	-20 to +40 °C
Excess temperature:	5 to 50 Kelvin
Programs:	60
Acceleration curves:	10 linear 10 quadratic 10 freely programmable
Deceleration curves:	9 linear 1 brakeless 10 quadratic 10 freely programmable
Integral:	9999 Exp 11 Swedberg
Radius:	max /min. s. chapter 1 2
Rotor and bucket part no.:	s. chapter 1.2
Dimensions:	
Depth (mm):	675
Width (mm):	410
Height (mm):	380
Weight (kg):	64
EMC (according to EN 55011):	Class B
Noise level (dBA):	66 < 63 (during pre-cooling)
Regular checks acc. to UVV VBG 7z	yes
Notes of user:	
Serial number:
Supply date:
Inventory number:
Location:
Responsibility:

The figures are valid for an ambient temperature of 23 °C +/- 2 °C and 230 Volt +/- 5 % The minimum temperatures achieved during run are < +4 °C and depend on type of rotor, speed and ambient temperature. (Allowable ambient temperature 10 °C - 35 °C; max. humidity of air 80 %)

1. General Information:

1.2 Accessories Suitable for SIGMA 3K 18

Part No.	Description	Max. speed (rpm)	Max. gravitational field (x g)
11133	Swing-out rotor for 4 round buckets, for the following accessories	5 500	5 411
13130	Round bucket , aluminium, with thread, for 3 Falcon-tubes 15 ml, closeable with sealing cap 17111, incl. sealing ring 16251	5 500	5 411
13104	Round bucket, aluminium, with thread, for the following round carriers and the 200 ml bottles 15202 and 15203	5 500	5 242
17111	Polycarbonate sealing cap for hermetic sealing of buckets 13104 and 13130		
13117	Round bucket, aluminium, for the following round carriers and the 200 ml bottles 15202 and 15203	5 500	5 242
17000	Round carrier, two-piece, indrilled, polyallomer, autoclavable		
17006	Round carrier for 12 RIA-tubes, Ø 12 x 55 up to 75 mm, polyallomer, autoclavable		
17007	Round carrier for 12 tubes 7 ml, Ø 12 x 100 mm, polyallomer, autoclavable		
17008	Round carrier for eg. 12 Eppendorf reaction vials 1,5 up to 2,2 ml, polypropylene, autoclavable		
17012	Round carrier for 6 tubes with screw cap 10 ml no. 15000, 15010 and 15019, polyallomer, autoclavable		
17013	Round carrier for 9 hemolyse tubes, max. Ø 12,9 x 85 mm, polypropylene, autoclavable		
17014	Round carrier for 12 hemolyse tubes, max. Ø 12,5 x 75 mm, polyallomer, autoclavable		

1. General Information:

Part No.	Description	Max. speed (rpm)	Max. gravitational field (x g)
17015	Round carrier for 7 tubes 15 ml, max. \varnothing 17 x 112 mm, polyallomer, autoclavable		
17018	Round carrier for 4 tubes with sealing cap, \varnothing 17/19,4 x 107 mm (eg. Monovettes), polyallomer, autoclavable		
17019	Round carrier for 3 Falcon-tubes 15 ml, polypropylene, autoclavable, suitable for 13104 without sealing cap		
17025	Round carrier for 2 tubes 25 ml, \varnothing 24 x 100 mm, polyallomer, autoclavable		
17027	Round carrier for 7 Vacutainer-tubes, \varnothing 12/16 x 75/80 mm, polypropylene, autoclavable		
17030	Round carrier for 2 tubes with screw cap 30 ml no. 15029, 15030, 15032, 15034, polypropylene, autoclavable		
17049	Round carrier for 1 Falcon-tube 50 ml, polypropylene, autoclavable		
17050	Round carrier for 1 tube 50 ml, \varnothing 34 x 100 mm, polyallomer, autoclavable		
17052	Round carrier for 1 tube with screw cap 50 ml no. 15051, 15052, 15054, polyallomer, autoclavable		
17085	Round carrier for 1 tube with screw cap 80/85 ml no. 15074, 15075, 15076, 15080, polyallomer, autoclavable		
17100	Round carrier for 1 tube 100 ml, \varnothing 45 x 100 mm, polyallomer, autoclavable		
17101	Round carrier for 1 polypropylene tube 100 ml no. 15102, polypropylene, autoclavable		
17125	Adapter for 1 tube with screw cap 125 ml no. 15125, polypropylene, autoclavable		

1. General Information:

Part No.	Description	Max. speed (rpm)	Max. gravitational field (x g)
11132	Swing-out rotor 28 x 15 ml complete, consisting of rotor 11133, 4 round buckets 13117, 4 carriers 17015 and 28 PS-tubes 15020, max. radius 14,9 cm, min. radius 5,2 cm	5 500	5 039
11130	Swing-out rotor with support for 150 ml stainless chromium steel buckets 13100	6 000	6 118
13100	Bucket 150 ml, stainless chromium steel, suitable for 1 tube 100 ml no. 15100, 15102, 15103 with rubber cushion 16100. Attention: There is an increased risk of glass breakage at speeds exceeding approx. 5 000 rpm		
11131	Swing-out rotor 4 x 150 ml complete, consisting of rotor 11130, 4 stainless chromium steel buckets 13100, 4 rubber cushions 16100 and 4 glass tubes 15100, max. radius 13,8 cm, min. radius 5,2 cm. Attention: There is an increased risk of glass breakage at speeds exceeding approx. 5 000 rpm	6 000	5 555
11136	Rotor for reaction vials (max. 60/120 pcs.) incl. cover, for carriers 14000 and 14002, max. radius 7,1 cm, min. radius 3 cm. Attention: The vessels could be damaged at speeds exceeding 13 000 rpm	14 500	16 689
14000	Casset for 20 reaction vials 0,25/0,4 ml, suitable for 11136, polyallomer, autoclavable		
14002	Casset for 10 reaction vials 1,5 up to 2,2 ml, suitable for 11136, polyallomer, autoclavable		
11224	Swing-out rotor for cytology, complete, with 4 buckets and carriers for different object carriers. The buckets with object carriers could be locked in 90° position, max. radius 11,3 cm	3 000	1 140

1. General Information:

Part No.	Description	Max. speed (rpm)	Max. gravitational field (x g)
11222	Swing-out rotor incl. 2 carriers for 2 - 6 microtitre plates 86 x 130 mm, max. radius 10,5 cm, min. radius 6,5 cm	3 000	1 107
11223	Swing-out rotor incl. 2 carriers for 2 - 6 microtitre plates 86 x 130 mm, max. radius 10 cm, min. radius 6,5 cm	4 000	1 788
11134	Swing-out rotor 4 x 10 ml incl. buckets for sealed tubes 15000, 15010, 15019, max. radius 9,8 cm, min. radius 2,7 cm	10 000	10 733
12111H	Angle rotor 10 x 10 ml for sealed tubes 15000, 15010, 15019, incl. hermetic aluminium lid, max. radius 7,6 cm, min. radius 2,8 cm, angle 35°	18 000	27 530
12150H	Angle rotor 6 x 50 ml for sealed tubes 15051, 15052, 15054, incl. hermetic aluminium lid, max. radius 8,4 cm, min. radius 2,1 cm, angle 25°	14 600	20 018
12110H	Angle rotor 12 x 1,5 up to 2,2 ml for eg. Eppendorf reaction vials, incl. hermetic aluminium lid, max. radius 6,4 cm, min. radius 3,1 cm, angle 45°	18 000	23 183
12154H	Angle rotor 24 x 1,5 up to 2,2 ml for eg. Eppendorf reaction vials, incl. hermetic aluminium lid, max. radius 8,2 cm, min. radius 5 cm, angle 45°	18 000	29 703
12131H	Angle rotor 30 x 1,5 up to 2,2 ml for eg. Eppendorf reaction vials, incl. hermetic aluminium lid, max. radius 10,0 cm, min. radius 6,7 cm, angle 45°	16 400	30 070
12153	Angle rotor 36 x 1,5 up to 2,2 ml for eg. Eppendorf reaction vials, 2 lines, max. radii 8,8/7,7 cm, min. radii 5,6/4,6 cm, angle 45°	16 000	25 186/22 038
12155H	Angle rotor 4 x 80/85 ml for sealed tubes 15074, 15075, 15076, 15080, incl. hermetic aluminium lid, max. radius 9 cm, min. radius 2,1 cm, angle 30°	14 500	21 155

1. General Information:

Part No.	Description	Max. speed (rpm)	Max. gravitational field (x g)
12156H	Angle rotor 8 x 50 ml for sealed tubes 15051, 15052, 15054, incl. hermetic aluminium lid, max. radius 9,4 cm, min. radius 3,3 cm, angle 25°	13 800	20 013
12157H	Angle rotor 20 x 10 ml for sealed tubes 15000, 15010, 15019, incl. hermetic aluminium lid, max. radius 9,8 cm, min. radius 5,9 cm, angle 25°	10 000	10 956
12158H	Angle rotor 6 x 30 ml for sealed tubes 15029, 15030, 15032, 15034, incl. hermetic aluminium lid, max. radius 7,8 cm, min. radius 2,3 cm, angle 30°	18 000	28 254
12159H	Angle rotor 6 x 80/85 ml for sealed tubes 15074, 15075, 15076, 15080, incl. hermetic aluminium lid, max. radius 9,7 cm, min. radius 2,5 cm, angle 25°	11 400	14 238
19776H	Angle rotor for 6 Falcon-tubes 50 ml, incl. hermetic aluminium lid, max. radius 9,3 cm, min. radius 3,1 cm, angle 25°	10 000	10 397
19777H	Angle rotor for 10 Falcon-tubes 15 ml, incl. hermetic aluminium lid, max. radius 9,3 cm, min. radius 3,7 cm, angle 25°	10 000	10 397

Adapters	Tubes	Steel Tubes
13000	Adapter , POM, for reaction vials 0,25/ 0,4 ml, suitable for 12110, 12131, 12153, 12154, 14002, 17008	
13002	Adapter, POM, for Eppendorf reaction vials 0,5/0,75 ml, Ø 7,9/10 x 28/31 mm suitable for 12110, 12131, 12153, 12154, 14002, 17008	
15005	Eppendorf reaction vials 0,5 ml, Ø 7,9/10 x 28/31 mm, 1 pack contains 100 pcs., suitable for 13002	

1. General Information:

Part No.	Description
15008	Eppendorf reaction vials 1,5 ml, 1 pack contains 100 pcs., suitable for 12110, 12131, 12153, 12154, 14002, 17008
15040	Eppendorf reaction vials 2,2 ml, 1 pack contains 100 pcs., suitable for 12110, 12131, 12153, 12154, 14002, 17008
15014	Reaction vials 0,4 ml (Beckman system), polypropylene, 1 pack contains 100 pcs., suitable for 13000, 14000
15000	Teflon tube 10 ml incl. screw cap, \varnothing 16,1 x 81,1 mm, suitable for 12111, 12157, 17002, autoclavable
15010	ditto, polycarbonate, autoclavable
15019	ditto, polyallomer, autoclavable
15020	Polystyrol tube 15 ml, \varnothing 17 x 100 mm, suitable for 17015
15021	Polypropylene stopper for 15020, 15023
15023	Polypropylene tube 15 ml, \varnothing 17 x 100 mm, suitable for 17015
15029	Teflon tube 30 ml incl. screw cap, \varnothing 25,3 x 92 mm, suitable for 12158, 17030, autoclavable
15030	ditto, polycarbonate, autoclavable
15032	ditto, polypropylene, autoclavable
15034	ditto, polyallomer, autoclavable
13055	Bucket 50 ml, stainless chromium steel, closeable with sealing cap 17054, \varnothing 28/34,5 x 101,5/104,5 mm incl. cap, suitable for 12150, 12156, 17052
17054	Sealing cap, stainless chromium steel, for 13055

1. General Information:

Part No.	Description
15049	Polycarbonate tube 50 ml, graduated, Ø 34 x 100 mm, suitable for 17050
15051	Teflon tube 50 ml incl. screw cap, Ø 28,5 x 107 mm, suitable for 12150, 12156, 17052, autoclavable
15052	ditto, polypropylene, autoclavable
15054	ditto, polycarbonate, autoclavable
13085	Tube 85 ml, stainless chromium steel, closable with sealing cap 17185, Ø 38,2/40 x 100/107 mm, incl. cap, suitable for 12155, 12159, 17085
17185	Sealing cap, stainless chromium steel, for 13085
15074	Polycarbonate tube 80 ml incl. special screw cap made of aluminium with seal for high speeds, Ø 38 x 108 mm, suitable for 12155, 12159, 17085, autoclavable
15075	Polycarbonate tube 80 ml incl. screw cap, Ø 38 x 112 mm, suitable for 12155, 12159, 17085, autoclavable
15076	ditto, polypropylene, autoclavable
15080	ditto, polyflor, autoclavable
15102	Polypropylene tube 100 ml, Ø 45 x 100 mm, suitable for 17101, 13100
15103	ditto, polycarbonate, suitable for 13100, 17100, 17101
15125	Polypropylene tube 125 ml incl. screw cap, Ø 50,5 x 99 mm, suitable for 17125
15202	Polypropylene bottle 200 ml incl. screw cap, Ø 56,6 x 104 mm, suitable for 13104, 13117
15203	ditto, polycarbonate

1. General Information:

Part No. Description

Glass tubes

15007	Glass tube 7 ml, Ø 12 x 100 mm, suitable for 17007
15027	ditto, graduated
15015	Glass tube 15 ml, Ø 16 x 100 mm, suitable for 17015
15024	ditto, graduated
15022	Corex tube 15 ml, Ø 17,5 x 104 mm, suitable for 12150, 12156 with 16018 and for 12155, 12159 with 16019, max. speed 7 000 rpm
15025	Glass tube 25 ml, Ø 24 x 100 mm, suitable for 17025
15026	ditto, graduated
15033	Corex tube 30 ml, Ø 24 x 105 mm, suitable for 12150, 12156 with 16030 and for 12155, 12159 with 16031, max. speed 7 000 rpm
15050	Glass tube 50 ml, Ø 34 x 100 ml, suitable for 17050
15056	ditto, graduated
15100	Glass tube 100 ml, Ø 44 x 100 mm, suitable for 13100, 17100, 17101
15106	ditto, graduated

Further accessories

16018	Rubber adapter for 15 ml Corex glass 15022, suitable for 12150, 12156
16019	Rubber adapter for 15 ml Corex glass 15022, suitable for 12155, 12159

1. General Information:

Part No.	Description
16030	Rubber adapter for 30 ml Corex glass 15033, suitable for 12150, 12156
16031	Rubber adapter for 30 ml Corex glass 15033, suitable for 12155, 12159
16100	Rubber cushion for stainless chromium steel bucket 13100
16910	Rubber plate for round carriers 17006, 17007, 17012, 17015, 17025
16911	Rubber plate for round carriers 17050, 17100
17111	Round polycarbonate sealing cap, clear, for bucket 13104, 13130
16251	Sealing ring 57 x 2 x 3 mm for bucket 13104, 13130
17971	Tool to remove the microtitre plates from rotors 11222, 11223
17914	Table for centrifuge made of chipboards with 2 doors and space for accessories, dimensions: w 650, d 680, h 470 mm The rubber feet of the centrifuge must be replaced by other feet.
17913	Fasteners for table 17914

1. General Information:

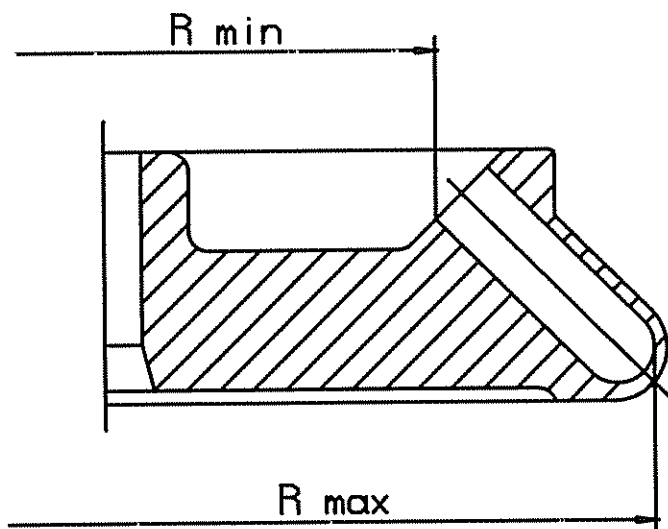
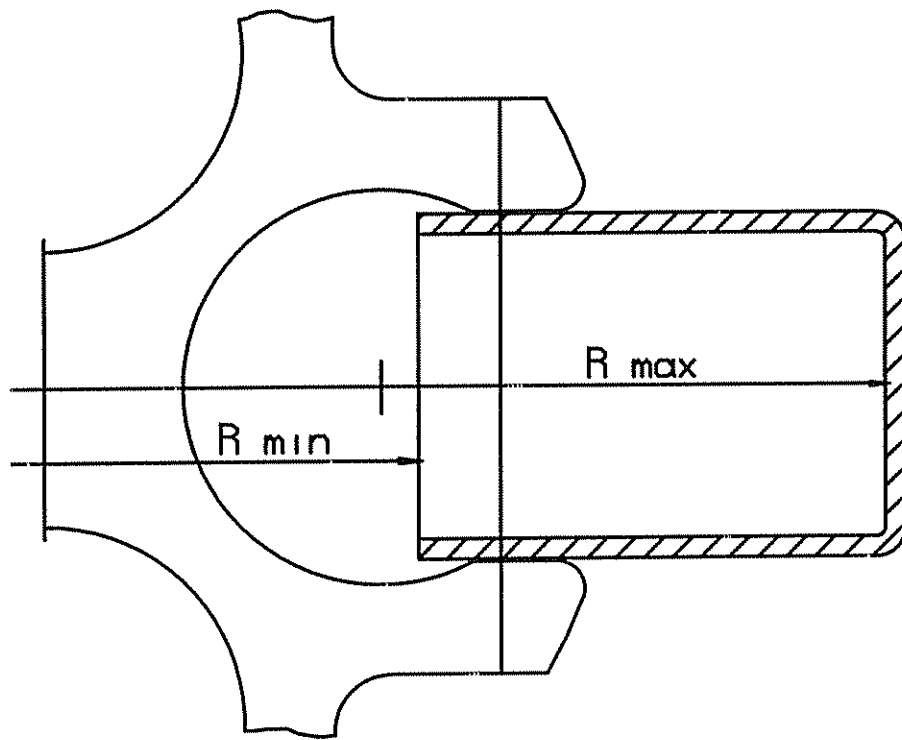

1. General Information:

1.3 Scope of Supply

The following belongs to the centrifuge:

1 Rotor spanner SW 10	Part No. 930 100
1 Tube grease for rotor trunnion pins	Part No. 70 284
20 ml slushing oil	Part No. 70 104

Documentation:

- 1 Short operating instructions
- 1 Operating instructions
- 1 "Rotor and Accessories, Operation and Use"
- 1 EU-Statement of Conformity
- 1 Certificate of Non-Contamination

Accessories according to your order, our order confirmation and our delivery note.

Rotor Part No.	Rotor No
.....
.....
.....
.....
.....
.....
.....
.....

1. General Information:

1.3 Scope of Supply

The following belongs to the centrifuge:

1 Rotor spanner SW 10	Part No. 930 100
1 Tube grease for rotor trunnion pins	Part No. 70 284
20 ml slushing oil	Part No. 70 104

Documentation:

- 1 Short operating instructions
- 1 Operating instructions
- 1 "Rotor and Accessories, Operation and Use"
- 1 EU-Statement of Conformity

Accessories according to your order, our order confirmation and our delivery note.

Rotor Part No.	Rotor No.
.....
.....
.....
.....
.....
.....
.....
.....

1. General Information:

1.4 Standards and Regulations

Please refer to the enclosed EU-Statement of Conformity.

1. General Information:

1.5 Safety Instructions

regarding operation of centrifuges with rotors of different max. speed, eg. angle rotors and swing-out rotors.

According to the German health and safety regulation UVV, VBG 7z the operator should take care of the following points:

1. According to § 19 of the UVV, VBG 7z the owner has to provide operating instructions based on those of the manufacturer and to inform the employees accordingly.
2. For safety reasons these operating instructions must clearly state that the stamped max. speed of the used rotor/bucket and the max. allowable filling quantity must not be exceeded.
3. If the density of the material exceeds 1.2 g/cm^3 , the max. speed of the centrifuge must be reduced respectively the instrument's control electronics automatically reduces the selected speed when a density of higher than 1.2 g/cm^3 is entered.
4. Operation of the centrifuge in hazardous locations is not allowed
5. During operation the centrifuge must not be moved. Leaning against or resting on the centrifuge is not allowed.
6. Do not spin explosive or highly inflammable materials.
7. Substances which could damage the material of the centrifuge, the rotors or the buckets anyhow must not be centrifuged or only under consideration of special safety measures. Infectious, toxic, pathogene or radioactive substances must be centrifuged in suitable rotors only.
8. Keep a clearance of at least 30 cm around the centrifuge. Dangerous materials of any kind must not be put down or stored in that area.

2. Description of Centrifuge:

2.1 General Outlay

The new generation of SIGMA laboratory centrifuges is equipped with newest state-of-the-art electronics and is driven by brushless, silent and long-life asynchronous motors.

The problem of carbon brush change is no longer existent and as there is no carbon dust pollution, operation in clean rooms is possible if the appropriate accessories are used.

2.2 Construction and Constructive Safety Measures

The centrifuge is built into an aluminium sheet housing. The opening to the rotor chamber is smaller than the chamber itself providing additional safety in the event of an accident. The centrifuge lid is also made of solid aluminium sheet steel with integrated heat insulation. From the back the lid is secured by solid shafts and at the front by a cover lock.

The bottom of the barrier ring is a multiple steel plate so that there is a solid safety case around the rotor chamber. The centrifuge stands on noise absorbing, elastic feet with optional devices for bench top fastening.

2.3 Drive

The drive motor is a well dimensioned asynchronous motor.

As there are no commutators, no carbon brush change is necessary, there is no carbon dust pollution and the noise level is low.

2.4 Data Input and Output

The input and output unit is a hermetically sealed foil keyboard with clearly distinguished keys. Easily readable displays and LED's are available and lead the operator through the wide range of applications.

Option:

A connection for a serial interface is possible so that an external personal computer with printer can be connected for control or recording.

2. Description of Centrifuge:

2.5 Electronics

The electronics controlled by three microprocessors allows extensive adaptations of the centrifuge to the different tasks. The following parameters can be programmed and called among others:

- Speed in steps of 1 rpm
- RCF in steps of 1 x g
- Input of centrifugal radii
- Input and measurement of integral
- Time operation:
 - a) 9 min, 59 sec
 - b) 9 h, 59 min
 - c) 9 days, 23 h
- Short-time operation
- Operation with preselected start time
- Temperature setting range between -20 °C and +40 °C
- Excess temperatures between 5 and 50 Kelvin
- Fixed deceleration and acceleration curves
- Free programming of deceleration and acceleration curves
- Saving, loading and altering programs
- Error messages recognized by the system and saved for service

2.6 Safety Devices

Apart from the passive safety devices due to the instrument's mechanical design there are the following active precautions for your safety:

2.6.1 Lid Lock, Cover Closing Device

The centrifuge can only be started when the lid is correctly closed. The cover lock must close. The lid can only be opened when the rotor has stopped. If the lid is opened by the emergency release during operation, the centrifuge will immediately switch off and decelerates brakeless up to standstill of the rotor. If the lid is open, the drive is completely separated from the mains supply, that means starting of the centrifuge is impossible (refer to point 8.5.4 "Emergency lid release").

2.6.2 Imbalance Monitoring System

In the event that uneven loading leads to imbalance, the drive is switched off during acceleration or during run.

2. Description of Centrifuge:

2.6.3 Excess Temperature in the Centrifuge Chamber

Once the temperature in the centrifuge chamber exceeds 50 °C, eg. due to a failure of the cooling device, the drive switches off. Restarting the centrifuge is only possible after cooling down.

2.6.4 Rotor Monitoring

During programming the rotor part no. and if required the bucket part no. must be entered. The computer checks, if the entered speed or the gravitational field is allowed for the rotor. Input errors are impossible (refer to point 8.3 "Entry limitations"). After starting, during the start-up phase, the computer additionally checks the identity of the rotor. **Attention: Please take care to enter the correct bucket part no. as the max. allowable speed could be exceeded by entering an incorrect bucket. This is not allowed.** If the rotor doesn't correspond to the programmed rotor no., STOP is carried out and an error message is issued. Restarting the centrifuge is only possible, when the rotor part no. has been corrected.

2.6.5 Standstill Monitoring

Opening of the centrifuge lid may only be possible, if the rotor is at standstill. This standstill is checked by the microprocessor and also by a second additional hardware circuit. Both monitoring devices must independently of each other have recognized that the rotor is at standstill before the lid can be opened.

2.6.6 System Check

An internal system check monitors data transmission and the sensor signals with regard to plausibility. The diverse malfunctions are recognized with utmost sensitivity, displayed as error message together with an error number and saved for service.

2.6.7 Earth Wire Check

For earth wire check there is a potential equalization screw at the rear panel of the centrifuge. An earth wire check can be carried out using an appropriate measuring instrument.

3. Installation, Start-up:

3.1 Unpacking of the Centrifuge

Open cardboard. Take out box containing accessories. Remove upper foam cushions. Lift centrifuge upwards with two persons.

Please keep case for possible transport of centrifuge later.

3.1.1 Transport Safety Device

The SIGMA 3K 18 has a transport safety device. Please remove the plastic cap from the centrifuge chamber and keep it for possible transport of the centrifuge.

3. Installation, Start-up:

3.2 Installation

3.2.1 Site

All energy consumed by the centrifuge is converted into heat and emitted into the ambient air. Therefore, sufficient ventilation is important. The air-ducts in the unit must be open. Also, the centrifuge shouldn't be positioned near radiators and direct insulation should be avoided.

A clearance of at least 30 cm around the centrifuge is necessary.

For normal operation the ambient temperature should not fall below 10 °C and not exceed 35 °C. The max. humidity of air is 80 %. During transport from cold to warmer places there will arise condensation water inside the centrifuge. It is important that there is enough time for drying before the centrifuge can be started again.

3.2.2 Connection

The operating voltage on the name plate must correspond to the local supply voltage!

SIGMA laboratory centrifuges are units of safety class I, DIN VDE 0700, and include a three wire power cord 2,5 m long with shockproof right angle plug.

3.2.3 Fuses on Site

The centrifuges must be protected typically with at least 16 A slow acting fuses

3.2.4 Bench Top Fastening

A special device for bench top fastening is available on request.

3. Installation, Start-up:

3.3 Insertion of Rotors and Accessories

1. Open centrifuge lid by pressing Lid-key K5.
2. Unscrew rotor tie-down screw from motor shaft (anticlockwise).
3. Lower the rotor straight down onto the motor shaft.
4. Tighten the tie-down screw (clockwise) with the rotor spanner so that the disc spring, if existing, is pressed together.

Fastening torque: 110/112/113/203/204/1K 15/2-15/2K 15: approx. 5 Nm
3-15/3K 15/3K 18/3K 30: approx. 7,5 Nm
4-10/4K 10/6-10/6K 10: approx. 10 Nm

In the event of frequent use the tie-down screw must be loosened by some turns and fastened again. **This should be done once a day or after approx. 20 cycles.** This ensures a proper connection between rotor and shaft (please refer to chapter 7.2 "Care and cleaning of accessories" as well).

5. Fill all positions of swing-out rotors with buckets. Take care of correct installation of buckets.
6. Use only appropriate vessels for the rotor (please refer to chapter 1.2 "Suitable accessories" as well).

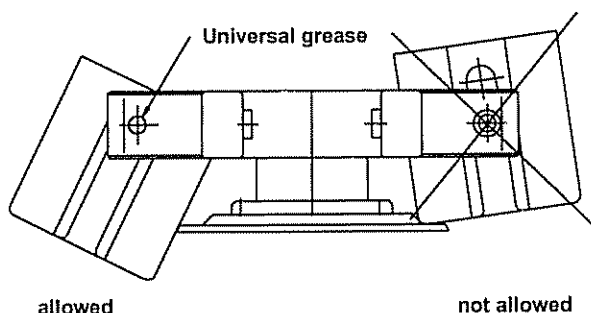

7. Fill vessels external to the centrifuge.
8. Put or screw on covers of vessels.
9. Opposite places of the rotors must always be loaded with same accessories and same filling.
10. In high speed centrifuges the plastic vessels must always be totally filled for the use with angle rotors to avoid distortion of vessels and leakages or loosening of the caps in case of partial filling. **Attention**, follow the special comments of chapter 1.5.
11. Attention: The centrifuge will absorb smaller differences in weight when loading the rotors. But it is recommended to balance the vessels as accurately as possible in order to ensure a run with minimal vibrations. Should the centrifuge be operated with very uneven load, the imbalance device will switch off the drive and an error message appears on the display.

3. Installation, Start-up:

The LED Imbalance (Ü1) of the monitoring panel is flashing (refer to 4.1 folding illustration at the end of the operating instructions).

12. Rotors with cover should always be run with their covers. The rotor cover is tightened with the rotor spanner. Correct fastening must be ensured.
Attention: The cover screw serves for fastening of the cover onto the rotor only, not for fastening of the rotor onto the drive! Before installation of cover, the correct fastening of the rotor fixing screw must always be checked using a spanner.

3.3.1 Fastening of Angle Rotors with Hermetically Sealed Lid

1. Screw rotor cover (2) onto rotor and tighten it.
2. Lower rotor with cover (2) onto motor shaft.
3. Put rotor tie-down screw (1) onto motor shaft and tighten using the spanner
4. The rotor can be run without cover (2) as well.
5. The rotor and cover seals (3) must be greased after cleaning.
6. Special instructions for the use of hermetically sealed rotors:

All rotors can be installed or removed with closed cover after loosening the rotor tie-down screw. All rotors are autoclavable (refer to chapter 7.6 "Sterilization and disinfection of rotor chamber and accessories"). To increase life of rotors and seals the rotors must be greased with slushing oil and the seals and thread areas with vaseline or grease after cleaning.

Attention!

Please follow the special comments of chapter 1.5.

3. Installation, Start-up:

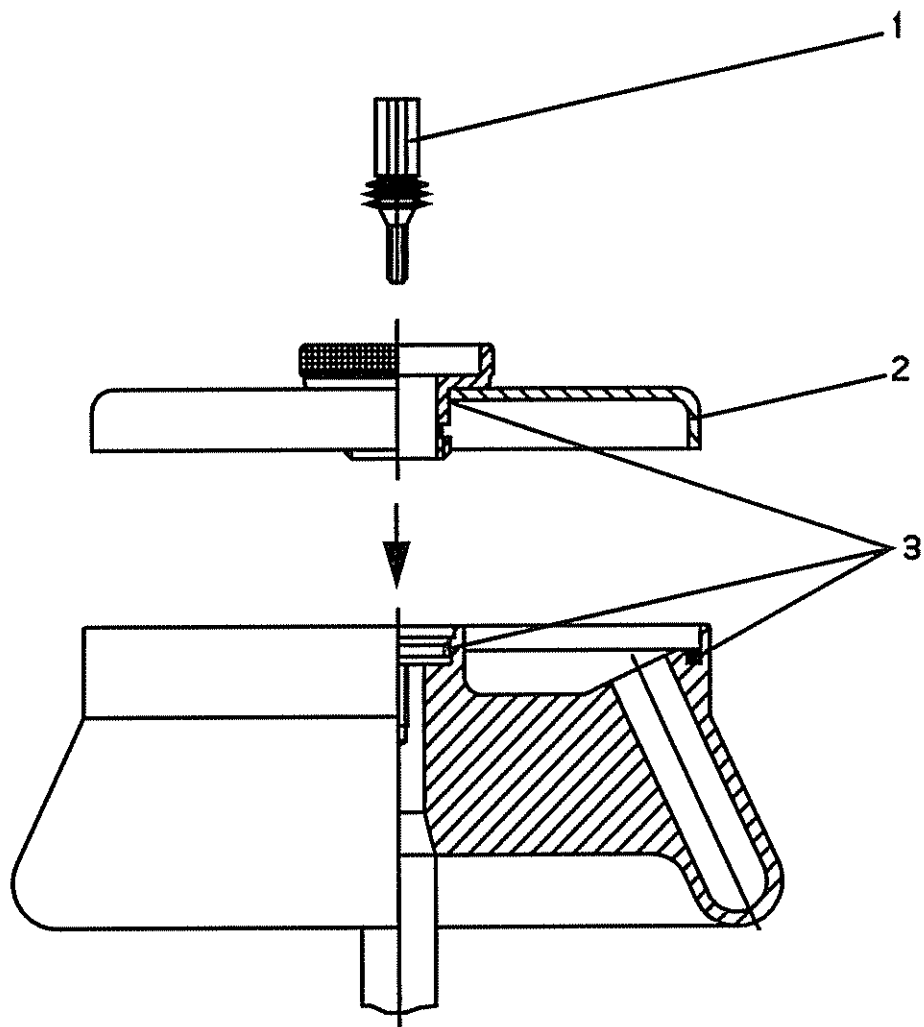

3. Installation, Start-up:

3.4 Initial Start-Up

Attention!

Before initial start-up please take care that your centrifuge is orderly installed (refer to chapter 3.2 "Installation").

3.4.1 Switching on of the Centrifuge

Press mains switch (at the back of the centrifuge). When power is applied for the initial use, default values will be displayed.

- The displays (TD, PD, ZD, DD) are illuminated.
- The speed display (DD) indicates "2000".
- The time display (ZD) indicates "2 00".
- The temperature display (TD) indicates "20" without pre-cooling. With activated pre-cooling the actual chamber temperature appears.
- The program panel (PD) indicates "--",
(the above mentioned indications are default parameters, if program no. "--" is loaded), i.e.:

- the centrifuge is to accelerate to 2000 rpm with curve no. 9,
- the centrifuge operation is terminated after 2 minutes,
- the cooling system is set to a temperature of 20 °C,
- deceleration of the centrifuge is carried out with curve no. 9,
- the values of the loaded program appear.

3.4.2 Opening Lid

Press Lid-key (K5).

- The lid opens.
- The display shows the set values of the selected program.

3.4.3 Insertion of Rotor

Put a rotor onto the shaft and fasten it by screwing the rotor tie-down screw onto the shaft. Please use the supplied rotor spanner (refer to chapter 3.3 "Insertion of rotor and accessories"). Please pay attention to the fact that during tightening the disc spring of the rotor tie-down screw, if existing, is pressed together and the screw is tightened.

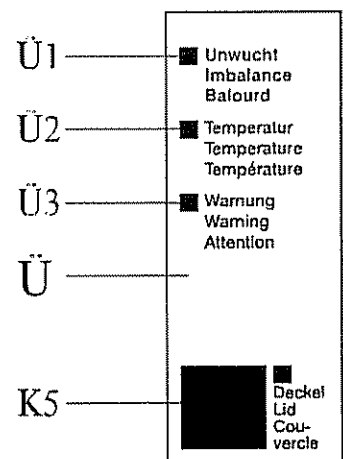

3. Installation, Start-up:

3.4.4 Selecting a Rotor or Bucket Number

Select LED "Rotor" (D3) by pressing the parameter key (DP) in the speed panel.

- LED "Rotor" (D3) is illuminated,
- a rotor part no. will appear on the speed display.

Pressing the Edit-key in the input panel activates the change mode (Edit-Aktiv-LED illuminated).

- Select the rotor number by pressing the cursor keys until the correct number is displayed in the speed display,
- if a swing-out rotor with several available buckets had been selected, flashing rotor LED and display of "buc" in the time panel after pressing the Enter-key or parameter key request for input of bucket number,
- terminate input by pressing the Enter-key,
- with the new rotor number resp. bucket number new set values may be displayed.

3.4.5 Starting and Stopping a Run

Close the lid.

- The LED's of the Start-key (K1) and the Short-key (K2) are illuminated, indicating that operation can be started.

Conditions

- Entries must be completed.
- No active faststop.

Press the Start-key (K1) (for optional methods please refer to chapter 4.3.1 "Key Short (K2)"),

- the LED of the Start-key (K1) will extinguish,
- the LED's of the Stop and Faststop-keys (K3, K4) are illuminated,
- the motor accelerates to the set speed with the preselected curve, LED K5 will extinguish,
- the speed display (DD) indicates the current rotor speed.

Stopping a run in progress

Press the Stop-key (K3),

- the Start-key LED is illuminated again, indicating that the operation can be restarted by pressing the Start-key,

3. Installation, Start-up:

- the motor decelerates according to the set deceleration curve until it comes to a standstill,
- the display continues to indicate the current operational data.

Or:

Press the Faststop-key (K4),

- the Start-key LED will not light up,
- operation cannot be continued by pressing the Start-key,
- the motor decelerates with maximum deceleration to a standstill,
- the display continues to indicate the current operational data.

For starting please open and close the lid.

The run is over,

- the time display (ZD) changes to "0",
- the Start-key LED is illuminated, indicating that operation can be restarted by pressing the Start-key,
- the motor decelerates with the set deceleration curve up to standstill,
- the display continues indicating the current operational data.

Press the Lid-key (K5),

- the lid opens,
- the set values of the selected program are displayed again.

Note!

In the event of problems please refer to chapter 8.5 "Error correction".

4. Operating Elements:

4.1 Operating Panel (Folding Illustration at the End of the Operating Instructions)

All settings of the centrifuge are accessed via the operating panel. The operating panel is divided into display panels and control panels.

4.2 Displays and Keys

- Speed panel (D)
- Time panel (Z)
- Program panel (P)
- Temperature panel (T)

The individual panels contain the following operator controls and displays:

Displays

(Displays are labelled by two letters, the latter one being a D: DD, ZD, PD, TD). The displays are located at the upper part of the panel. Because of a high intensity contrast, they are easy to read and allow for a simultaneous presentation of important data of the centrifuge operation (eg. speed, time, temperature, program no. etc.).

Light Emitting Diodes (LED)

(The LED`s are labelled by the letter of the corresponding panel and numbered in sequential order: eg. D1, D2, ...). The LED`s are arranged vertically below the displays. One of the LED`s is constantly on. It identifies the selection in the corresponding display.

Parameter Keys

(The keys are labelled with two letters, the latter being a P: TP, PP, ZP, DP). The parameter key is located at the bottom right corner of each panel. Pressing a parameter key of an active panel changes to the next parameter of this group. By pressing a parameter key of another panel the cursor changes to this panel. In the alteration mode the cursor is activated.

4. Operating Elements:

Input Keys

The input keys are divided in:

- Alteration keys
- Cursor keys
- Edit-key
- Enter-key
- Delete-key



Alteration Keys

The alteration keys are labelled with ▲▼

With these keys values can be increased ▲ or decreased ▼ by depressing the ▲ or the ▼ key.

Short pressing of the key results in one single counting step, holding the key in continuous steps with increasing speed. Counting terminates at the end of the respective value but can be continued by pressing the counting key again, resulting in an overflow.

Cursor Keys

The cursor keys are labelled with ◀▶

The cursor position through the displays can be selected using the cursor keys. This is particularly advantageous, if extensive value alterations are necessary.

Edit-Key

The Edit-key is labelled with "Edit".

The Edit-key switches to the alteration mode (Edit-Aktiv-LED on).

The display changes from actual value display to set value display. After pressing the Edit-key again the alteration mode is terminated, possible changes of parameters are not saved.

Furthermore, saved programs can be loaded using the Edit-key.

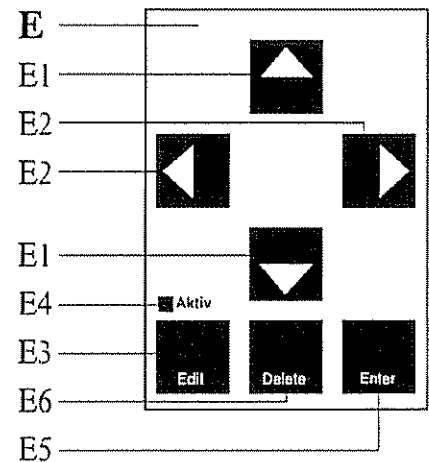

4. Operating Elements:

Enter-Key

The Enter-key is labelled with "Enter".

With the Enter-key the parameter values are read and saved. They are also available after power off. The alteration mode finishes by pressing the Enter-key.

Delete-Key

The Delete-key is labelled with "Delete".

With the Delete-key programs, curves or intervals are deleted in the alteration mode by pressing the Delete-key and verified with the Enter-key.

4. Operating Elements:

4.3 Control Panels

4.3.1 Command Panel (K)

The centrifuge operation is started via the command panel. Keys can be pressed when their LED is on.

Start-key (K1)

This key can be used for the following:

- starting centrifuge operation,
- terminating a previously started deceleration process and restarting centrifuge,
- shifting to short-run at preselected speed. Pressing Start-key continuously for the time of the short run leads to acceleration max. to the set speed **with the reselected acceleration curve** and after release deceleration **with the preselected deceleration curve**. Max. range 9 min 59 sec.

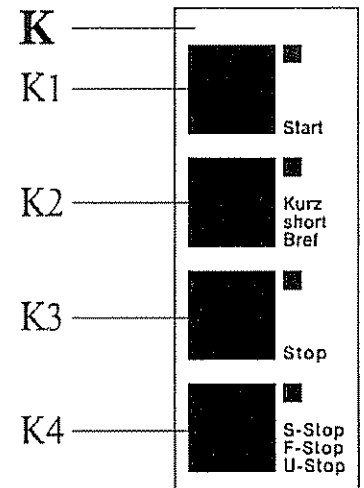

The centrifuge can be started when

- the lid is closed,
- no incorrect entries have been made,
- no LED's are flashing (except Rotor LED),
- the Start-LED is on,
- the Faststop-key has not been previously pressed,
- entries are finished.

Key Short (K2)

With this key the centrifuge can be accelerated to the max. speed of the rotor **with max. acceleration** and decelerated **with the max. deceleration curve** after releasing the key. Max. range 9 min. 59 sec.

Stop-key (K3)

This key can be used to terminate a run. The centrifuge decelerates according to the preset curve to a standstill. Deceleration can be terminated by pressing the Start-key again.

4. Operating Elements:

Faststop-key (K4)

Pressing this key decelerates the centrifuge as fast as possible. This deceleration process cannot be stopped, the centrifuge comes to a standstill in any case. Restarting is only possible after opening and closing the lid.

Lid-key (K5)

This key is used to open the lid. This can only be executed if

- the centrifuge has come to a standstill,
- the lid LED is on.

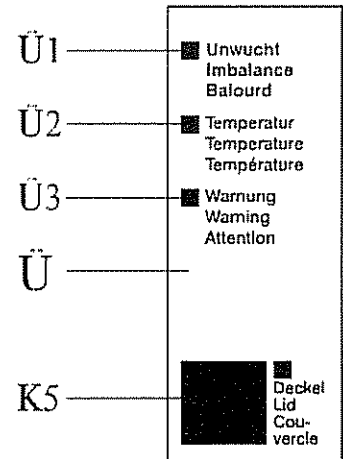

4. Operating Elements:

4.3.2 Key-Operated Switch (S)

With the key-operated switch the use of the centrifuge can be limited. The three switch positions are marked by LED's:

- Fix (S1)** - Starting, "Short" and "Open cover" during standstill only. The parameter keys remain active for calling the parameters.
- Universal (S2)** - Unrestricted operations.
- Stand-by (S3)** - The running centrifuge can be stopped only. The display extinguishes when the run is over. The "Stand-by" LED is illuminated. The refrigerating machine remains on with active pre-cooling.

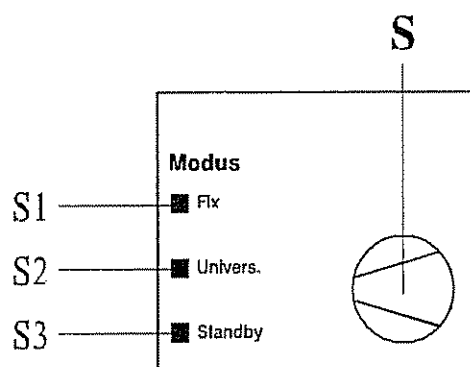

4. Operating Elements:

4.4 Display Panels

4.4.1 Speed Panel (D)

Speed (D1)

With entering a speed, the set value of the centrifuge speed is selected. After starting the centrifuge the current actual speed of the rotor is displayed.

RCF (D2)

The relative centrifugal force (abbrev RCF) is an indication of the stress the sample is exposed to during a run. This value can be preset. The resulting speed is automatically calculated and displayed. After starting the run, the actual relative centrifugal force is displayed, if the RCF parameter is selected.

Rotors/Buckets (D3)

Rotor LED illuminated:

The desired rotors is selected via the alteration keys. All available rotors are offered for selection in the display in sequential order by pressing these keys. After selection of the desired rotor and display in the speed panel input is terminated by pressing the Enter-key. Pay attention to max. allowable speed.

After pressing the Enter-key or parameter key the Rotor LED is flashing, if various buckets are available for the set rotor. After selection of the desired bucket and display in the speed panel input is terminated by pressing the Enter-key.

Attention: Please take care that the correct bucket part number is entered as otherwise the max. allowable speed could be exceeded. This is not allowed.

Density (D4)

If the density of the liquid to be centrifuged exceeds 1.2 g/cm³, the corresponding value must be entered for safety reasons. The max. speed is decreased accordingly. Input range 1.2 to 9.9 (please refer to chapter 8.4.2 "Density").

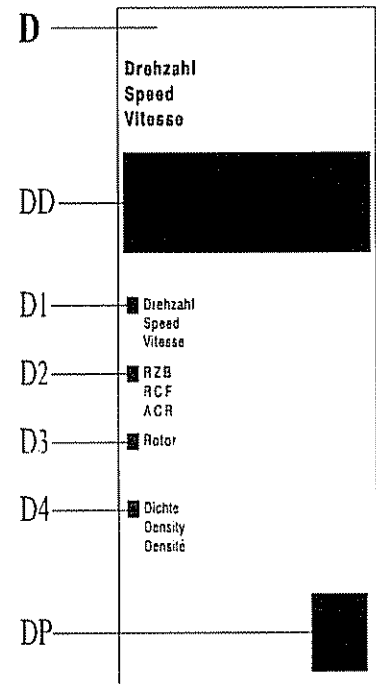

4. Operating Elements:

4.4.2 Time Panel (Z)

Time (Z1)

During standstill, this display shows the programmed time. During the operation of the centrifuge, the remaining run-time is displayed in

- minutes and seconds
- hours and minutes
- days and hours.

The time ranges can be selected via the alteration keys. The cursor must be set to the time range LED's. Time is defined as the period from starting the centrifuge to the beginning of deceleration, the maximum value is 9 d 23 h. Deceleration is activated after the programmed time is over.

Integral (Z2)

The integral is describing the dynamic stress the sample is exposed to. In order to display the high integral values, the exponential notation is used. It is covered by two displays: the speed display shows the four-digit mantissa, the time display the two-digit exponent. For further details please refer to chapter 5.6.3 "Specifying an integral".

Radius (Z3)

The radius is the horizontal distance between the middle of the rotor shaft and the inner bottom of the bucket.

Normally, the maximum value is automatically loaded. Entry of different radii in the range of R max and R min for calculation of the gravitational field is possible (please refer to chapter 1.2 "Suitable accessories").

The radii are displayed in cm. For further details please refer to chapter 5.6.1 "Specifying a relative centrifugal force (RCF)".

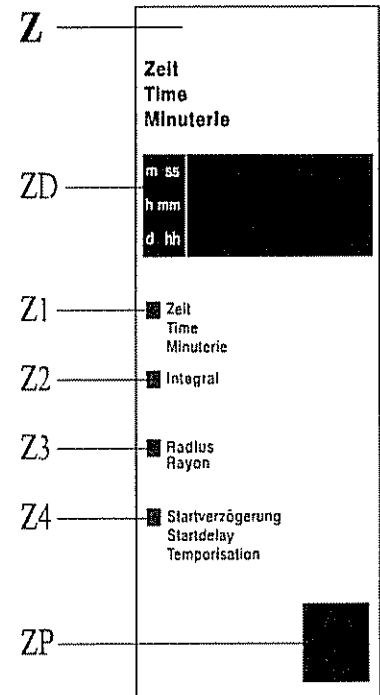

4. Operating Elements:

Start Delay (Z4)

The Start-delay can be set in minutes and seconds, hours and minutes or day and hours.

The entry 0 is deactivating the start-delay.

With a start-delay > 0 the time up to the start of the centrifuge will be displayed in the time panel by pressing the Start-key, the Start-delay LED is flashing. When the set time has elapsed, the centrifuge is started. Pressing the Stop-key deactivates the start-delay mode, the start-delay period is set to 0. The start-delay period is not saved with the programm data.

4. Operating Elements:

4.4.3 Temperature Panel (T)

Temperature (T1)

The centrifuge is temperature-controlled by a cooling system. When a run is started, there is a temperature difference between the sample and the rotor which is minimized after a certain operating period has passed.

During an operation, the temperature display indicates the actual temperature inside the rotor chamber. After pressing the Edit-key and the parameter key the set value is displayed in the temperature panel.

By entering a temperature, the desired temperature for the centrifuge chamber is set. Temperatures between -10 °C and +40 °C can be preselected.

As soon as the lid is opened, the cooling system is disconnected in order to avoid icing of the rotor chamber.

Precooling of the rotor below 0 °C during standstill is not recommended. Differences between actual and displayed temperature and icing of compressor would be the result. This would reduce life of the compressor. For lower rotor chamber temperatures we recommend precooling at 1000 rpm.

With an ambient temperature of +23 °C the obtainable lowest temperature is < +4 °C at maximum speed eg. with rotors 12159 and 11133.

(A change of the limit values can cause deviations.) The obtainable temperatures depend on type of rotor, speed and ambient temperature.

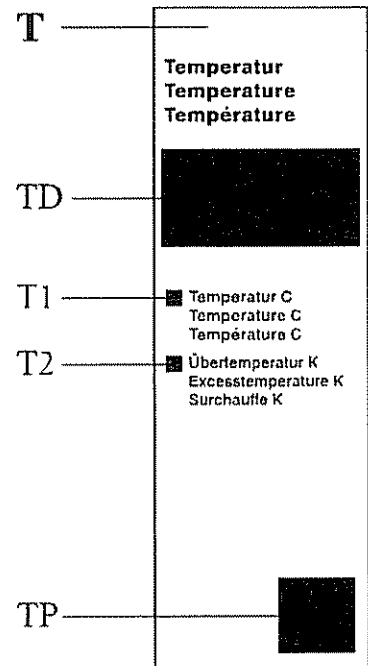

4. Operating Elements:

Excess Temperature (T2)

With the entry of an excess temperature a maximum chamber temperature relative to the set temperature is defined which should not be exceeded. The temperature range for the excess temperature is between 5 and 50 K above the set temperature. The centrifuge can be started outside these limits as well. Values eg.: Set value +4 °C, actual value +25 °C, set excess temperature 10 Kelvin. If the temperature does not decrease during operation, a malfunction of the refrigerating machine is recognized and the run is terminated. If the temperature decreases, the microprocessor assumes that the set temperature will be reached during run. The LEDs in the monitoring panel are indicating the operating states (please refer to chapter 4.4.5 "Monitoring panel").

4. Operating Elements:

4.4.4 Program Panel (P)

Program (P1)

A program is loaded by entering a program code number. After power on, the last active program is loaded. Programs can be changed, saved again or deleted. For details please refer to chapter 5 "Programming".

Acceleration (P2)

The acceleration number selects an acceleration curve which the centrifuge follows until the final speed has been reached. Three different slopes are available:

0 ... 9	linear slope
10...19	quadratic slope in the speed range up to 1000 rpm
20...29	freely programmable curves (if programmed)

Curves 0 to 19 are set by the manufacturer and cannot be changed by the user. Please refer to chapter 8.1 "Slope of the specified curves, linear curves" and 8.2 "Quadratic curves". Curves 0 to 9 are linear, curves 10 to 19 are quadratic in the speed range up to 1000 rpm. In the speed range exceeding 1000 rpm the acceleration is linear.

The acceleration is expressed by the curve slope. For example: curve no. 8 is steeper than curve no. 7, i.e. the centrifuge will reach the final speed within a shorter period.

Curves 9 and 19 apply the maximum acceleration to the centrifuge. These curves represent an exception. The centrifuge accelerates with maximum torque. The acceleration time only depends on the inertia of the rotor.

Acceleration curves 20 to 29 are user defined and can be applied over the entire speed range. They can only be selected if a curve had been entered with the corresponding number before. For further details please refer to chapter 5.7 "Programming variable acceleration and deceleration curves".

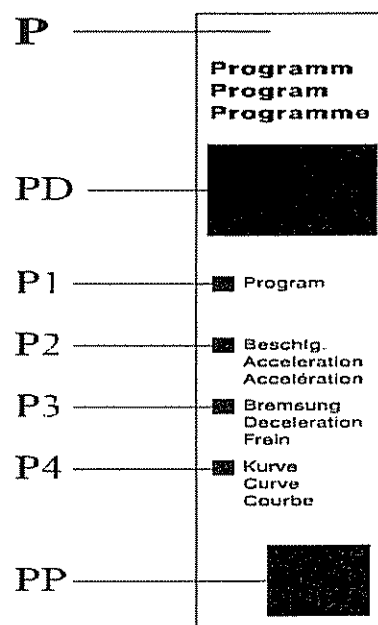

4. Operating Elements:

Deceleration (P3)

The deceleration number selects a deceleration curve which decelerates the centrifuge to standstill. The deceleration curves are inverted images of the acceleration curves and are labelled with identical numbers (except curve 0 = brakeless).

Curve (P4)

By selecting the Curve-LED the programming mode for freely programmable curves is activated (please refer to chapter 5.7 "Programming variable acceleration and deceleration curves").

4. Operating Elements:

4.4.5 Monitoring Panel (Ü)

In this panel possible warning limits during operation are indicated by three illuminated or flashing monitoring and warning LED's.

"Imbalance" (Ü1)

Illuminated:

Flashing:

- The imbalance LED has two control functions:
- Warning in the event of slight imbalance (warning limit < imbalance < cutoff limit). Run can be continued.
- Run cannot be continued due to excessive imbalance (imbalance > cutoff limit). Run is terminated with max. deceleration.

Reason:

Improper loading or malfunction during operation (eg. glass breakage) resulting in an uneven run.

"Temperature" (Ü2)

Illuminated:

Flashing:

- During run or precooling the temperature in the rotor chamber exceeds the entered excess temperature. The temperature LED is illuminated. If after 5 minutes the temperature will not decrease, the run is terminated and the LED is flashing.
- The entered cutoff limit cannot be reached within 5 minutes or is exceeded during operation. The run is terminated.

"Warning" (Ü3)

- This LED warns of the danger of glass breakage which might occur with the selected speed.

Note!

For further details please refer to chapter 8.5 "Error correction".

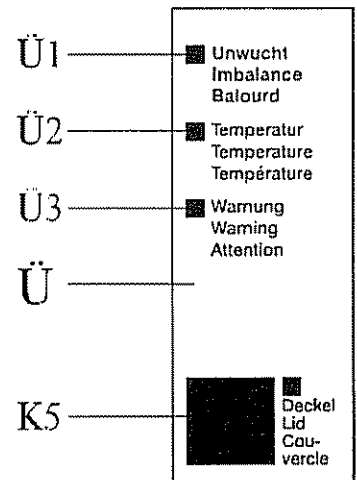

5. Programming:

What is considered a program?

A program contains all data that are required and can be selected for the operation of the centrifuge.

In other words, a program contains a sequence of key operations in a memory. This sequence of key operations can be loaded with one single operation to run the centrifuge with these values. A program is useful if a defined centrifuge operation should be repeated under same conditions.

A program saves time and helps to avoid entry errors which often could occur with repeated entries.

The program numbers are displayed in the program panel (PD). Max. 60 programs can be stored under numbers 0 - 59. Please use the forms of appendix 8.8 and 8.9.

The centrifuge is supplied with a standard program "--". With this program, an operation is possible at any time (please refer to chapter 3.4 "Initial start-up"). This standard program is overwritten with the entry of the first user program.

5. Programming:

5.1 Selection, Display and Alteration of Program Parameters

Set values

When in standstill and with open cover, the centrifuge displays the last entered values (TD, PD, ZD, DD) in the temperature, program, time, and speed panel displays.

Actual Values

During the operation, the displays indicate the actual values.

The LED's (T1, T2, P1-4, Z1-4, D1-4) below the displays indicate the parameters which the displays are currently showing. As a standard, the upper LED's are illuminated. The speed is displayed in the speed panel, the run time in the time panel, the temperature in the temperature panel and the program in the program panel.

The value of each of the parameters can be changed prior to a centrifuge operation by executing the following.

Press the Edit-key; the Edit-Aktiv-LED is illuminated. The third digit of the speed display is flashing.

You are in the alteration mode.

Press the parameter key (TP, PP, ZP, DP) of the display panel where the parameter should be changed (refer to chapter 4.1, paragraph "Cursor keys").

Select your parameter.

- This is executed by pressing the parameter key. The parameter values of the corresponding panel are displayed from top to bottom.
- The LED of the selected parameter illuminates.
- The digit of the display which should be changed is flashing, indicating that the user is still in the alteration mode.

Enter the new data via the alteration keys and save by pressing the Enter-key or recall existing data by renewed operation of the Edit-key.

- If a change has been made, the new value is stored. The programm number in the program panel is replaced by "--" showing that an unstored or altered program is used.

5. Programming:

5.2 Loading a Program (Calling up a Saved Program)

A program stored with a specific program number should be loaded, ie. it should be called up for starting the centrifuge:

- Activate the alteration mode by pressing the Edit-key.
- Activate the program panel (P) by pressing the program parameter key (PP). LED program is illuminated.

The available programs are displayed.

Select a program number using the alteration keys (program no. 0 - 59). A standard program "--" is always existent. The standard program "--" and stored programs can be called up using the alteration keys. Unused programs are displayed in the temperature panel "---", the time panel "---" and the speed panel "---". The individual parameters of each program can be called using the parameter keys. The program is loaded by pressing the Edit-key. The last active program or the parameter changed last is automatically loaded when the centrifuge is restarted.

If you want to change from program "--" to a stored program (eg. program no. 6), select the desired program number in the alteration mode and load program by pressing the Edit-key.

For further details please refer to chapter 5.1 "Selection, display and alteration of program parameters".

The centrifuge can be started using the selected program by pressing the Start-key (K1).

5. Programming:

5.3 Changing and Saving a Program

Each change of a parameter, eg. time, temperature, acceleration curve etc. is a program change. In the program display (PD) "--" is displayed instead of the program number.

- Select alteration mode by pressing the Edit-key.
- Press the parameter key (DP, TP, ZP) of the panel where a parameter should be changed. The digit to be changed is flashing. The parameter could be changed.
- Activate the program panel (P) by pressing the program parameter key (PP).
- Select program number (0 - 59). Unused program numbers are displayed in the temperature panel "---", the time panel "---" and the speed panel "----".
- Press Enter-key.

Saving the program, if no program was existing under the selected number.

Display of "Pr", "quit" if a program is already existing under the selected number with the following options:

- Enter-key will overwrite the existing program
- Edit-key will terminate the storing process

Note!

Invalid entries or such exceeding the allowed limits are not accepted (please refer to chapter 8.3 "Entry limitations").

5.4 Deleting a Program

After activation of the alteration mode the program numbers to be deleted are selected using the alteration keys. The program "--" cannot be deleted. A program is deleted by pressing the Delete-key and by confirming "del" using the Enter-key.

5.5 Changing a Program During Centrifuge Operation

When the centrifuge is running, the following parameters can be changed:

- Speed
- RCF
- Run-time
- Time mode
- Deceleration curve while the centrifuge does not decelerate
- Acceleration curve while the centrifuge does not accelerate
- Temperature

Select the parameter to be changed using the parameter keys (TP, ZP, DP).

- The actual values are displayed.

Change the value using the Edit-key and the alteration keys (please refer to chapter 5.1 "Selection, display and alteration of program parameters").

- The actual values are displayed.

5. Programming:

5.6 Programming the Relative Centrifugal Force, Density and Integral

A change of these parameters automatically results in recalculation and change of other parameters, because there is a direct mathematical relation between them (please refer to chapter 8.4 "Mathematical relation").

Entry limits cannot be exceeded when using the alteration keys.

5.6.1 Specifying a Relative Centrifugal Force (RCF)

The relative centrifugal force, abbr. RCF, is a measure for the rotational force on the sample. Its magnitude depends on the radius and the speed (refer to chapter 8.4.1 "Relative centrifugal force (RCF)").

During the operation, the RCF value (actual value) is continuously calculated and can be displayed by calling the parameter. Therefore, a control over the actual force can be obtained.

During standstill, the RCF value (set value) is calculated when a speed or a rotor number is entered. The RCF can be preset. The resulting final speed is then calculated and displayed.

Example:

- Switch to the speed panel, activate RCF and enter the new RCF data (eg. a lower value than the one calculated from the final speed).
- Change to the speed panel.
- The final speed has been recalculated.
- Change to the time panel and enter a smaller radius.
- The RCF value has been decreased.
- Increase the final speed controlling the RCF at the same time until the originally set RCF value is obtained again.

Result:

By decreasing the radius, a higher final speed is required in order to obtain an identical RCF value.

5.6.2 Specifying a Density

If the density of a liquid to be centrifuged exceeds 1.2 g/cm^3 , the max. speed for the rotor reduces.

The centrifuge is able to calculate the reduced max. speed, if the parameter "Density" in the speed panel is activated (LED D4 illuminated) and the higher density is entered via the alteration keys (E1). The entry range of the density value is between 1.0 and 9.9.

A value exceeding 1.2 g/cm^3 decreases the maximum possible final speed (please refer to chapter 8.4.2 "Density").

Note!

When working with sedimentation constants, the required time constant can be calculated with the aid of the integral, if the initial speed had been reduced due to excessive density (please refer to chapter 5.6.3 "Specifying an integral"). Calculation proceeds as follows:

- Enter initial program data
- Read corresponding integral value.
- Enter actual density (the initial speed and the initial integral value are reduced).
- Enter initial integral value (the corresponding run-time is calculated).

The run can be started with the initial sedimentation constants.

5.6.3 Specifying an Integral

The integral is a measure of the dynamic load the sample is exposed to. This value is displayed in exponential form. The four-digit mantissa is displayed with a preceding "n" in the speed display and the two-digit exponent with a preceding "E" in the time display.

During operation, the integral is constantly determined. Its value depends on the speed and the elapsed centrifuge run-time. The value increases constantly (please refer to chapter 8.4.3 "Integral").

The actual values of the integral can be displayed during a run or thereafter.

It is possible to set an integral.

The following factors are considered when calculating an integral.

- Run-time
- Final speed
- Acceleration curve
- Deceleration curve

If a new final speed is entered directly before the entry of a set integral, the centrifuge automatically determines the total run-time. In all other cases the final speed is determined.

Automatic conversion of the run-time is also useful, if the max. speed must be reduced by reason of high specific density of the material and thus the run-time must be increased (refer to chapter 5.6.2 "Specifying a density").

Example:

- Specify new final speed data, run-time values and acceleration curves in sequential order.

The resulting integral changes.

- Specify a smaller integral.

The resulting final speed decreases.

- Specify an integral after having altered the final speed.

The resulting run-time changes.

5.7 Programming Variable Acceleration and Deceleration Curves

Apart from 20 fix acceleration and deceleration curves, curves are freely programmable as well. Up to 10 different curves can be stored under no. 20 - 29 (please refer to chapter 4.4.4 "Program panel - acceleration").

Up to 10 intervals can be specified in an acceleration or deceleration curve. An interval is defined by its run-time and the speed to be obtained at the end of the interval. The final speed of the last interval should correspond to the operating speed for the centrifuge run. If the final speed of the last interval does not correspond to the operating speed the centrifuge calculates the acceleration time from the set curve slope (change of speed/time interval). For the first interval, a quadratic resp. linear acceleration can be preselected via the alteration keys "q" in the temperature panel indicates quadratic acceleration, "L" linear acceleration. The following intervals are always linear.

Only acceleration curves are programmed. The deceleration curves are inverted images. Each acceleration curve is also applicable as a deceleration curve.

Activate the curve mode for programming:

- Activate the alteration mode by pressing the Edit-key.
- Select LED curve in the program panel using the parameter key (PP), LED curve is illuminated.
- Press the alteration keys (E1). The curve mode is active. This mode can only be left by pressing "Enter" (curve is saved) resp. "Edit" (changes are refused).
- The last active curve no. is displayed in the program panel resp. curve 20 during initial programming. When pressing the alteration keys (E1) the display changes to the next available curve number. A desired curve number can be entered via the alteration keys.

The last digit of the temperature display shows the step number "0", the digit in front of it "q" for quadratic or "L" for linear curve of the first step. Pressing the alteration keys changes from "q" to "L" after the parameter key in the temperature panel (TP) had been pressed.

The speed display (DD) shows the obtainable speed per interval.

The time display (ZD) shows the run-time of the interval in minutes/seconds, hours/minutes or days/hours after which the centrifuge should reach the set interval speed.

5. Programming:

The temperature display: "q" for quadratic acceleration
"L" for linear acceleration
(0 - 9) number of intervals

With a new curve the speed and time displays are showing "0"

With the cursor keys (E2) any display position can be selected, if the corresponding value can be changed. The flashing value can be changed via the alteration keys (E1). The time ranges in the time panel can be changed via the alteration keys. In the event of too short intervals the max. interval speeds are adapted.

Setting speed and time for an interval:

The interval number is selected in the temperature panel via the alteration keys. If an interval contains no data, higher interval numbers cannot be selected.

The values for an interval can be set in the time and speed panel. The max. possible speed depends on the time selection and the speed values of the adjacent intervals. The acceleration calculated from the set speed and time values of the adjacent intervals must not exceed the maximum acceleration. Due to this check it is not possible to exceed the maximum speed resp. the shortest time value.

Comment

The max. speed of the curve is below the set operating speed. After reaching the end of the curve the centrifuge will accelerate to the set speed value and vice versa with the acceleration value the curve followed at the end.

5.7.1 Deleting Intervals

If the number of intervals of a curve should be reduced, the corresponding interval no. is selected using the alteration keys. This and all following intervals are deleted via the Delete-key (E6).

5.7.2 Changing a Programmed Curve

Select the position to be changed in the curve mode using the cursor key (E2). The corresponding digit is flashing.

The value can be entered via the alteration keys (E1). If all curve numbers are allocated, new entries can be made by overwriting or changing existing parameters (please refer to chapter 5.3 "Changing and saving a program").

5. Programming:

5.7.3 Example: Specifying a Program with a Freely Programmable Curve

An acceleration curve is programmed under a number between 20 and 29. Its absolute final speed should be 3100 rpm. The speed should be obtained in three interval steps. The total interval period is 4 minutes, the total run-time 6 minutes, temperature 20 °C.

Interval	Type	Time (min)	Speed (rpm)	Comment
0	q	1	1000	quadratic acceleration within 1 min. to 1000 rpm
1	L	2	2000	linear acceleration within 2 min. to 2000 rpm
2	L	1	3100	linear acceleration within 1 min. to 3100 rpm

(see speed-time-slope, picture 1)

Condition: Input of final speed, time and temperature.

Proceeding (only during standstill):

- Press Edit-key: Edit-mode active.
- Press programm parameter key (PP) until curve LED is reached. -
- Press alteration key (E1): Curve mode active
- Press temperature parameter key (TP): Interval no. is flashing (0).
- Press left cursor key (E2): L (linear) is flashing.
- Press alteration key (E1): Select "q" für quadratic acceleration in interval no. 0.
- Press time parameter key (ZP): Time panel is flashing, set 1 minute via E1/E2.
- Press speed parameter key (DP): Speed panel is flashing, set 1000 rpm via E1/E2.
- Press temperature parameter key (TP): Interval no. 0 is flashing.
- Press upper alteration key (E1): Interval no. 1 is flashing.

- Input of "1." and "2." interval as interval "0".

- Save via "Enter". Freely programmable curve 20 has been entered and will be available when required.

- After selection of the desired acceleration curve the run can be started by pressing the Start-key (K1).

5. Programming:

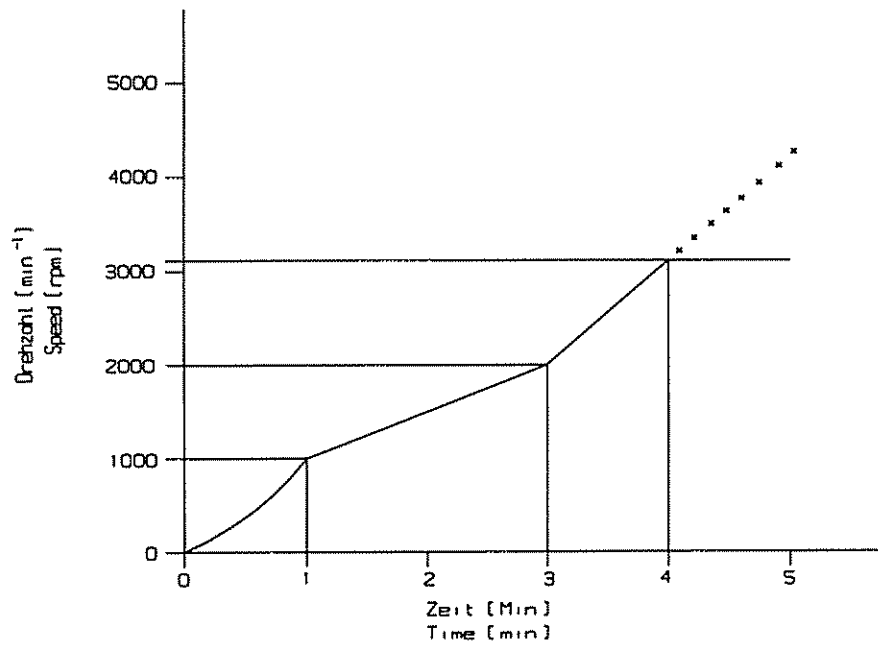

Picture 1, Speed-Time-Slope

5. Programming:

5.8 Pre-Cooling

Pre-cooling is activated, if the preselected set temperature is below the actual temperature. The temperature is regulated to the set value.

Conditions: - Power on
- Lid closed

6. Notes for Centrifugation:

6.1 Practical Notes for Centrifugation

1. Locate centrifuge horizontally on a level surface.
2. Ensure safe location.
3. Keep at least 30 cm free space around the centrifuge.
4. Provide for sufficient ventilation.
5. Tighten rotor firmly onto motor shaft.
6. Avoid imbalance.
7. Load opposite buckets with same accessories.

8. Centrifugation with low capacity:
The vessels should be placed symmetrically so that the buckets and their suspensions are loaded evenly. Loading an inner or outer position of the bucket only is not allowed (see illustration). Even angle rotors should be loaded symmetrically to same weight.

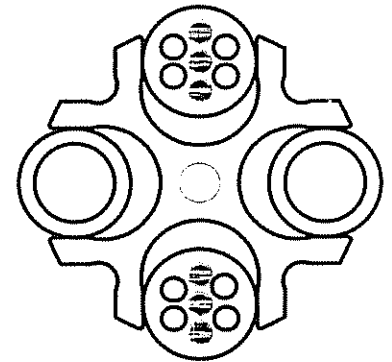

Centrifugation with different tubes:
Working with different tube sizes is possible. Opposite places must be loaded with the same vessels (see illustration).

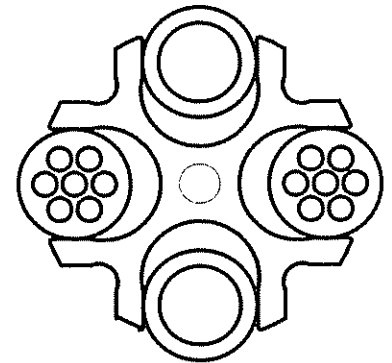

9. Load all positions of swing-out rotors.
10. Load vessels outside the centrifuge.
11. Please pay attention to the max. speed of glass tubes. At speeds over 4 000 rpm there is an increased breaking glass hazard (see warning LED (Ü3)).
12. Fill vessels carefully to same weight. Imbalances would result in increased wear of bearings.
13. Grease joints of buckets and rotor pins in swing-out rotors.
14. Use perfect accessories only.

6. Notes for Centrifugation:

15. Avoid corrosion to accessories by careful maintenance.
16. Spin infectious material in sealed rotors and buckets only.
17. Do not spin explosive or highly inflammable materials.
18. Record all program data, refer to forms of appendix chapter 8.8 and 8.9.
19. When centrifuging substances with a density $> 1,2 \text{ g/cm}^3$ the allowable max. speed must be reduced (refer to chapter 8.4.2 "Density").

6. Notes for Centrifugation:

6.2 Forbidden Centrifuging Operations

1. Operation of not carefully installed centrifuge.
2. Operation without front or back panels.
3. Operation by non authorized personnel.
4. Operation with rotor not installed properly (refer to chapter 3.3).
5. Operation with incompletely loaded swing-out rotor or angle rotor with interchangeable buckets.

A rotor must always be loaded completely, empty places are not allowed!
Opposite buckets or carriers may nevertheless be empty. Mixed loading is allowed, if opposite places are loaded with same buckets and carriers of same weight.

6. Operation with overloaded rotors.

The load for a rotor is limited by its design and the max. speed (see rotor/bucket engraving) and must not be exceeded. The rotors are intended for liquids of max. homogeneous density of 1.2 g/cm³ if centrifuged at max. speed. If liquids of higher density are used, the speed must be reduced accordingly (refer to chapter 8.4 "Mathematical relation").

7. Operation with rotors, buckets and carriers showing corrosion or other defects.
8. Operation of very corrosive substances which can cause damages to material and effect mechanical strength of rotors, buckets and carriers.
9. Operation of rotors and accessories not allowed by the manufacturer, except commercial vessels of glass or synthetic materials. The use of poor commodity goods is not recommended. At high speeds breaking glass or bursting vessels can cause dangerous imbalances.
10. Operation in hazardous locations.
11. Operation with vessels of improper size.
12. Centrifugation of improper material.
13. Operation with partially filled plastic tubes in high-speed angle rotors.
14. Lifting or moving of the centrifuge during operation. Leaning against or resting on the centrifuge is not allowed.

6. Notes for Centrifugation:

15. Do not place potential dangerous material - eg glass vessels containing liquids - near the centrifuge.
16. Attention: Do not open cover and/or reach into rotor chamber unless the rotor is at standstill. Never attempt to override the lid interlock system while the rotor is spinning.
17. Do not spin substances which could react upon the supply of high energy during centrifugation.
18. Do not spin explosive or highly inflammable materials.
19. Substances which could damage the material of the centrifuge, the rotors or the buckets anyhow must not be centrifuged or only under consideration of special safety measures. Infectious, toxic, pathogene or radioactive substances must be centrifuged in suitable rotors and vessels only.

7. Care and Maintenance:

7.1 Care and Cleaning of Centrifuge

Please use soap water or other water-soluble, mild agents for cleaning. Avoid corroding and aggressive substances. Do not use alkaline solutions or solvents or agents with abrasive particles. Remove product particles from the rotor chamber using a cloth or paper towel. It is recommended to open the cover when the centrifuge is not in use so that moisture can evaporate. **If there is the risk of toxic, radioactive or pathogene contamination, special safety measures must be kept.**

7.2 Care and Cleaning of Accessories

For care of accessories special safety measures must be considered as these are measures ensuring operational safety at the same time.

Buckets, trunnions and also synthetic buckets are produced exactly in order to withstand the permanent high stress with high gravitational fields.

Chemical reactions as well as stress-corrosion (combination of changing pressure and chemical reaction) can effect or destroy the metals. Hardly detectable cracks on the surface expand and weaken the material without visible signs. When detecting a visible damage of the surface, a crack, a mark or any other change, also corrosion, the part (rotor, bucket etc.) must be replaced immediately.

In order to avoid corrosion, rotor incl. tie-down screw and cover seal, buckets and carriers must be cleaned and greased regularly with the supplied slushing oil (part no.: 70104 for 20 ml slushing oil). The rotor tie-down screw must be greased using the supplied grease (part no : 70284).

Cleaning of accessories should be carried out external to the centrifuge once a week or preferably after every use. The rubber cushions should be removed from buckets and carriers. After this the parts should be dried with a soft cloth or also in a drying chamber at approx. 50 °C. **If there is the risk of toxic, radioactive or pathogene contamination, special safety measures must be kept.**

Especially aluminium parts are extremely corrosive. A neutral cleaning agent with a pH-value between 6 and 8 should be used for such parts. Alkaline agents exceeding pH 8 must be avoided. Especially aluminium parts must be greased regularly with slushing oil. This procedure essentially increases life time and reduces corrosion.

Careful maintenance increases life time and avoids premature failure of the rotor. Corrosion or resultant damages which are caused by insufficient care do not constitute a warranty claim.

7. Care and Maintenance:

7.3 Rotor Pins

The trunnion pins of the rotor should always be greased as only this ensures evenly swinging of buckets and thus quiet run of the centrifuge (part no. 70284 Grease).

7.4 Glass Breakage

In case of glass breakage all glass particles must be carefully removed. Rubber inserts have to be cleaned carefully and possibly be replaced. If a problem has occurred, the following has to be considered:

Glass particles in the rubber cushion will cause glass breakage again.

Particles on the rotor pins prevent buckets and carriers from swinging evenly which will cause an imbalance.

Glass particles in the centrifuge chamber will cause metal abrasion due to the strong air circulation. This dust will not only pollute the centrifuge chamber, the rotor, the buckets, the carriers and the material to be centrifuged but also damage the surfaces of the accessories, the rotors and the centrifuge chamber.

In order to totally remove the glass particles and the metal dust from the rotor chamber, it is advisable to grease the upper part of the centrifuge chamber with eg. Vaseline. Then the rotor should rotate for some minutes at a moderate speed. The glass and metal particles will now collect at the greased part and can easily be removed with a cloth together with the grease. If necessary repeat this procedure.

7.5 Care and Cleaning of the Condenser

A lamellar condenser is used to cool the compressed refrigerant. It is installed in the back part of the centrifuge and cooled with air.

The location for the centrifuge should therefore be as clean as possible, ie. dirt, dust etc. should not prevent the air from streaming through the condenser and obstruct heat transfer. Dust on the condenser pipes and the lamella will reduce heat exchange and decrease the performance of the refrigerator.

The condenser should therefore be regularly checked for dirt and cleaned if necessary. Generally blowing of the lamella with compressed air from inside and outside is sufficient (or a simple hoovering with a vacuum cleaner).

7. Care and Maintenance:

7.6 Sterilization and Disinfection of Rotor Chamber and Accessories

All usual disinfectants like eg. Sagrotan, Buraton or Terralin (to obtain at chemist's shops) can be used. The centrifuges and the accessories consist of different materials. A possible incompatibility must be considered. For sterilization by steam resistance to temperature of the individual material must be checked. Please contact your laboratory safety officer regarding proper methods to use. **If dangerous materials are used, the centrifuge and the accessories must be disinfected.**

Time/temperature conditions during autoclaving

Absolute pressure kPa	Steam temperature		Min. dwell time min
	Nominal temperature °C	Range °C	
225	136,0	134-138 aluminium	3
150	127,5	126-129 aluminium	10
115	122,5	121-123 aluminium,plastic	15
75	116,5	115-118 aluminium,plastic	30

Principally we want to point out that for centrifuging of eg. infectious material hermetically sealed buckets should be used in order to avoid that the centrifuge is contaminated.

7.7 Checks by Operator

The operator has to pay attention that important parts of the centrifuge necessary for safety are not damaged.

This especially refers to:

1. Motor suspension
2. Centricity of the motor shaft
3. Fastening of the trunnions in the rotor
4. Accessories, especially changes of structure like corrosion, cracks, material abrasion etc.
5. Screw connections

Furthermore, the earth wire must be checked regularly.

8.1 Slope of Specified Curves, Linear Curves

- The slope of a specified acceleration curve is defined as the time required to accelerate the rotor by 1000 rpm.
- With linear and quadratic slopes, curves are numbered in the direction of increasing acceleration (from right to left).
- The deceleration curves are inverted images of the acceleration curves with the same numbers (except curve 0).
- Curve 0 decelerates brakeless.

Comment: The acceleration time depends on the moment of inertia of the rotor.

Linear Curves (0 - 9)

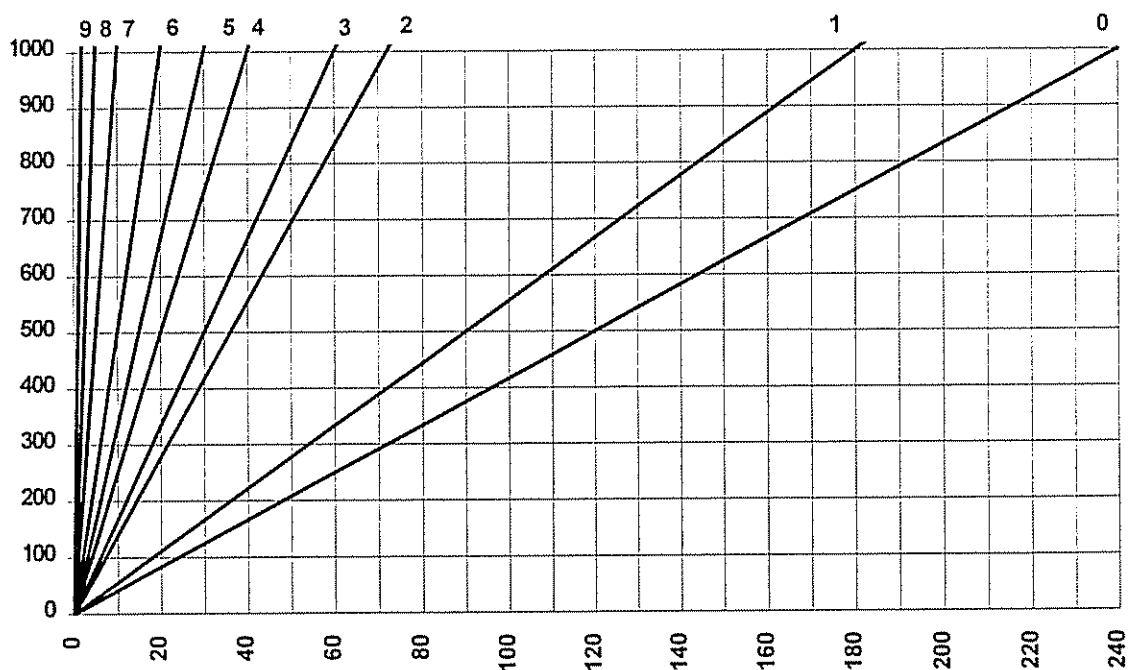

Figure 2

The curve 9 is a special case compared with the other curves. The centrifuge accelerates with max. torque. The acceleration time only depends on the moment of inertia of the rotor.

8. Appendix:

Linear curve no.	Slope
0	240 sec./1000 rpm.
1	180 sec./1000 rpm.
2	120 sec./1000 rpm.
3	60 sec./1000 rpm.
4	40 sec./1000 rpm.
5	30 sec./1000 rpm.
6	20 sec./1000 rpm.
7	10 sec./1000 rpm.
8	5 sec./1000 rpm.
9	0,9 sec./1000 rpm.

8.2 Quadratic Curves

- The deceleration curves are inverted images of the acceleration curves with the same numbers.

Quadratic Curves (10 - 19)

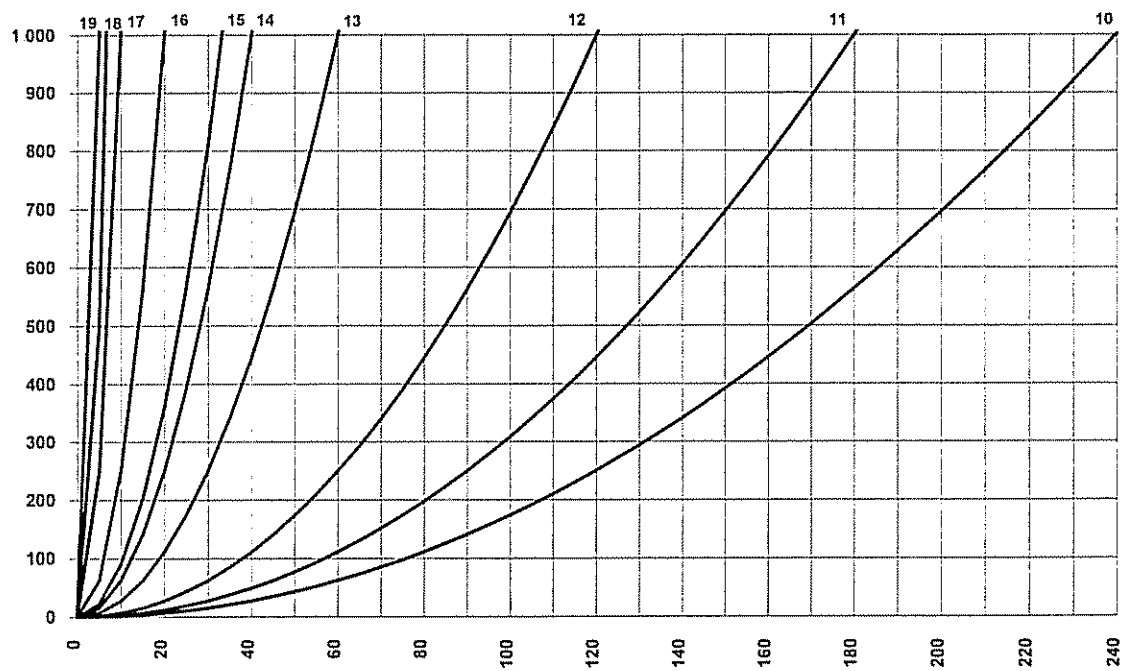

Figure 3

The curve 19 is a special case compared with the other curves. The centrifuge accelerates with maximum torque. The acceleration time only depends on the moment of inertia of the rotor.

8. Appendix:

Quadratic curve no.	Time up to 1000 rpm	Slope from 1000 rpm linear
10	240	120 sec./1000 rpm.
11	180	90 sec./1000 rpm.
12	120	60 sec./1000 rpm.
13	60	30 sec./1000 rpm.
14	40	20 sec./1000 rpm.
15	30	15 sec./1000 rpm.
16	20	10 sec./1000 rpm.
17	10	5 sec./1000 rpm.
18	5	2,5 sec./1000 rpm.
19	0,9	0,5 sec./1000 rpm.

8.3 Entry Limitations

Valid entries or area limits could depend on:

- Type of centrifuge
- Rotor
- interdependent parameters

All entry limits are automatically checked. When reaching a limit the counting operation is stopped.

Interdependent parameters are limited further with a change of the corresponding parameter. When using the alteration keys, limit errors are impossible. With the alteration of a parameter, the corresponding parameter is recalculated. The recalculated parameter is indicated by a flashing parameter-LED. If the changed parameter is selected, the recalculated value is displayed.

8.4 Mathematical Relation

8.4.1 Relative Centrifugal Force (RCF)

The parameters speed, RCF and the diameter of the rotor are interrelated via the following formula.

$$\text{RCF} = 11,18 * 10^{-6} * r * n^2$$

If two values are given, the third value is determined by the equation. If the speed or the rotation radius are changed, the resulting RCF will be recalculated. If the RCF is altered, the speed under consideration of the radius is adapted accordingly.

8.4.2 Density

If the density of the liquid is higher than 1.2 g/cm³, the allowed maximum speed of the centrifuge is calculated according to the following formula:

$$n = n_{\max} * \sqrt{(1 / \text{Gamma})}$$

8.4.3 Integral

The integral is describing the dynamic and speed-dependent stress to the sample during centrifuge operation.

During a run the actual integral is constantly calculated and displayed.

To assist the user when entering new speed-time curves, the set integral is determined. With freely programmable curves, the speed-time course is defined per interval.

$$I = \int_0^{\tau} Q^2 dt = \int_0^{\tau} (\pi / 30)^2 * n^2 dt = (\pi / 30)^2 \int_0^{\tau} n^2 dt$$

Due to small deviations between the set and actual speed during the acceleration phase differences between the set and actual value of the integral might occur. With extremely long run-times, especially with small speed values, the calculation of the actual integral could be incorrect.

Dimensions:

- n in rpm
- r in cm
- RCF without dimension
- I in 1/s
- Gamma in g/cm³

8.5 Error Correction

Most of the errors can be reset by power off/on. In the event of a short power supply failure during a run, this run is interrupted and can be continued by pressing the Start-key.

No indication on the display:

Actions:

- No voltage in the socket?
 - Power cord plugged in and line voltage present?
 - Input fuse ok?
 - Power switch on?
 - Key operated switch in position „Stand by“?
- Check fuse in mains supply.
 - Plug in power cord correctly.
 - Replace input fuse (see nameplate for rating).
 - Switch on power.
 - Turn key switch to “Universal”.

8.5.1 Centrifuge cannot be Started

a) Start-key LED not illuminated:

- Edit-Aktiv-LED illuminated.
 - Lid-LED not illuminated.
- Edit-Active-Mode is left by pressing the Enter-key or the Edit-key.
 - Close lid. Lid locks must close.

b) Start-key LED illuminated:

- Power off/on. If error occurs again, call service.
- Pay attention to start delay.

8.5.2 Centrifuge Decelerates during Operation

a) Imbalance-LED (Ü1) flashing:

- Rotor is loaded unevenly.
 - Centrifuge tilted.
 - Drive error (mechanical damage).
 - Centrifuge was moved during operation.
- Balance loading.
 - Align centrifuge.
 - Call Service.
 - Restart after opening and closing lid.

b) Temperature LED (Ü2):
LED flashing.

- Excessive chamber temperature.
- Excess temperature has been exceeded.
- Sensor connection cable defective.
- Let cool down.
- Check preselection.
- Call Service.

c) Start-key LED not illuminated:
Lid-LED not illuminated:

- Cover cannot be closed properly.
- Power off, open lid via emergency lid release (refer to chapter 8.5.4).

d) Start-key LED not illuminated:
Lid-LED illuminated:

- Edit -mode active.
- Edit mode is left by pressing the Enter-key.

e) Start-key LED illuminated:
Lid-LED illuminated:

- Start-delay active.
- Power off/on, if error occurs again, call service.
- Pay attention to start-delay.

f) General error:

- Installed rotor is different from entered rotor number.
- After power on an error number 69 to 77 is displayed.
- Correction of rotor number.
- These error numbers indicate an error in the internal permanent memory. Error could eg. occur in the event of a power supply failure during saving.

8.5.3 Lid cannot be Opened/Closed

- a) Slightly lift the lid when opening.
- b) Lid lock unlocked, call service.

8.5.4 Emergency Lid Release

In the event of a power supply failure it is possible to manually open the lid.

At the upper left panel there is a stopper which can be removed eg. with a screw driver. The lid can be released by pulling the visible string.

Attention!

The lid may only be unlocked and opened when the rotor is at standstill.

8. Appendix:

8.6 Error Codes

Error no.	Kind of error	Measures	Comment
1-62	Internal error	<ul style="list-style-type: none">• let slow down• power off/on	
69-77	EEPROM error	<ul style="list-style-type: none">• let slow down• power off/on	ATTENTION: Saved curves and programs could have been deleted.
78	Lid does not close	<ul style="list-style-type: none">• power off/on• remove foreign matter	
79	Faulty log identification	<ul style="list-style-type: none">• press lid key• close lid rapidly• check log opening for impurities	
80	Lid electronics defective	<ul style="list-style-type: none">• contact Service	
81	Rotor spins with open cover	<ul style="list-style-type: none">• let slow down• close lid• power off/on	
82-83	Lid does not open	<ul style="list-style-type: none">• power off• emergency lid release	
84	Excess temperature heat sink	<ul style="list-style-type: none">• let cool down• provide for better ventilation• power off/on	
85	Excess temperature centrifuge chamber (> 50 °C)	<ul style="list-style-type: none">• let cool down• provide for better ventilation• power off/on	
87	Actual temperature > 45 °C resp. < -20 °C	<ul style="list-style-type: none">• provide for better ventilation	
88	Excess temperature switch activated (temp. > 70 °C)	<ul style="list-style-type: none">• provide for better ventilation• refrigerating machine defective	
90-96	Sensor defective	<ul style="list-style-type: none">• power off/on	
98	Faulty rotor identification	<ul style="list-style-type: none">• check rotor	
99	Incorrect rotor	<ul style="list-style-type: none">• check rotor and set rotor resp. bucket identification	

Should it not be possible to repair the failure, please contact Service

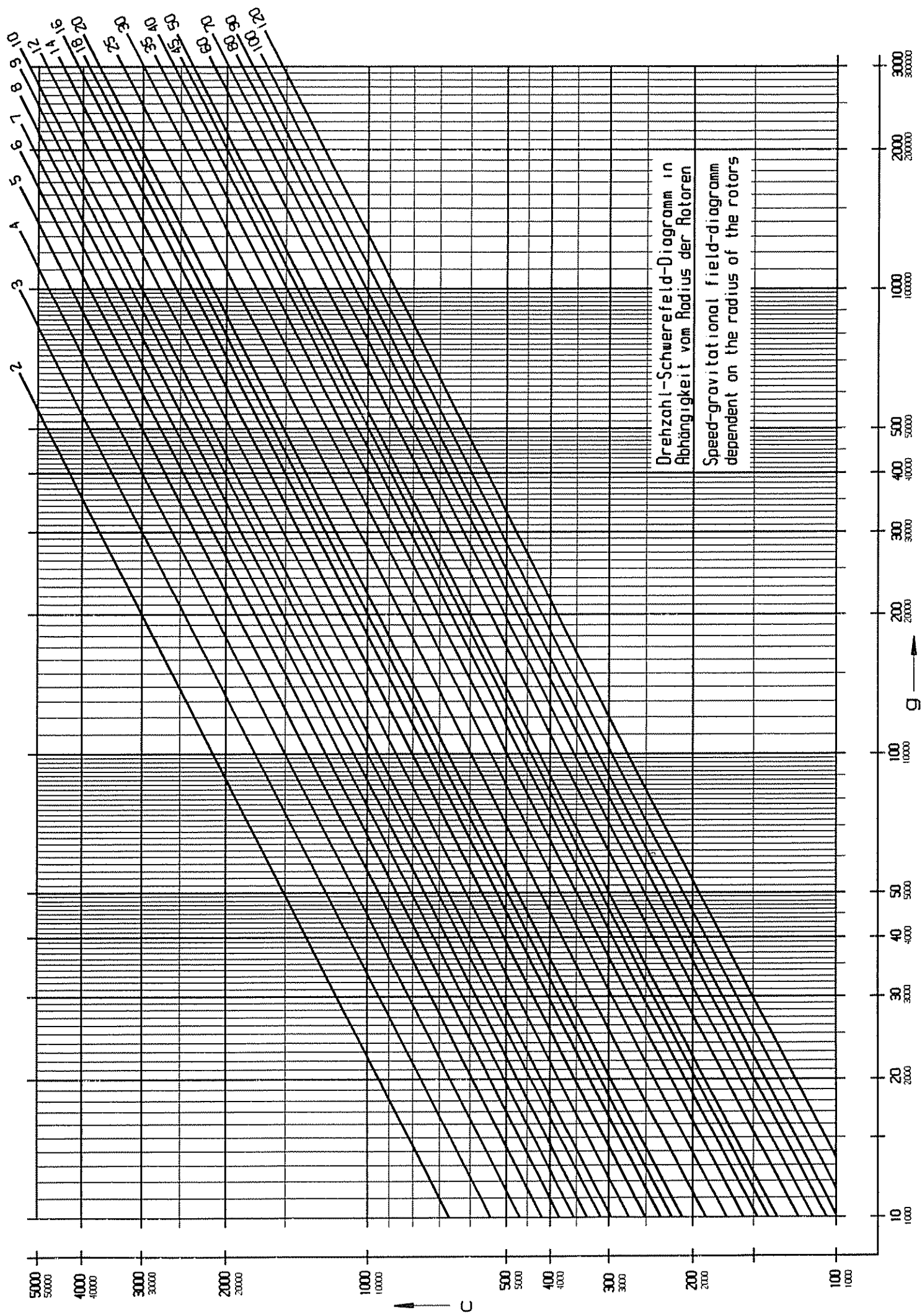

Drehzahl-Schwerefeld-Diagramm in
 Abhängigkeit vom Radius der Rotoren
 Speed-gravitational field-diagramm
 dependent on the radius of the rotors

Program Data:

8.8 Program No.:

Used for

.....
.....
.....
.....

Alteration:

.....
.....

by:

.....

Date:

.....

Speed

.....

Gravitational field

.....

Rotor

.....

Bucket

.....

Made on:

.....

by:

.....

4.1 Operating Panel

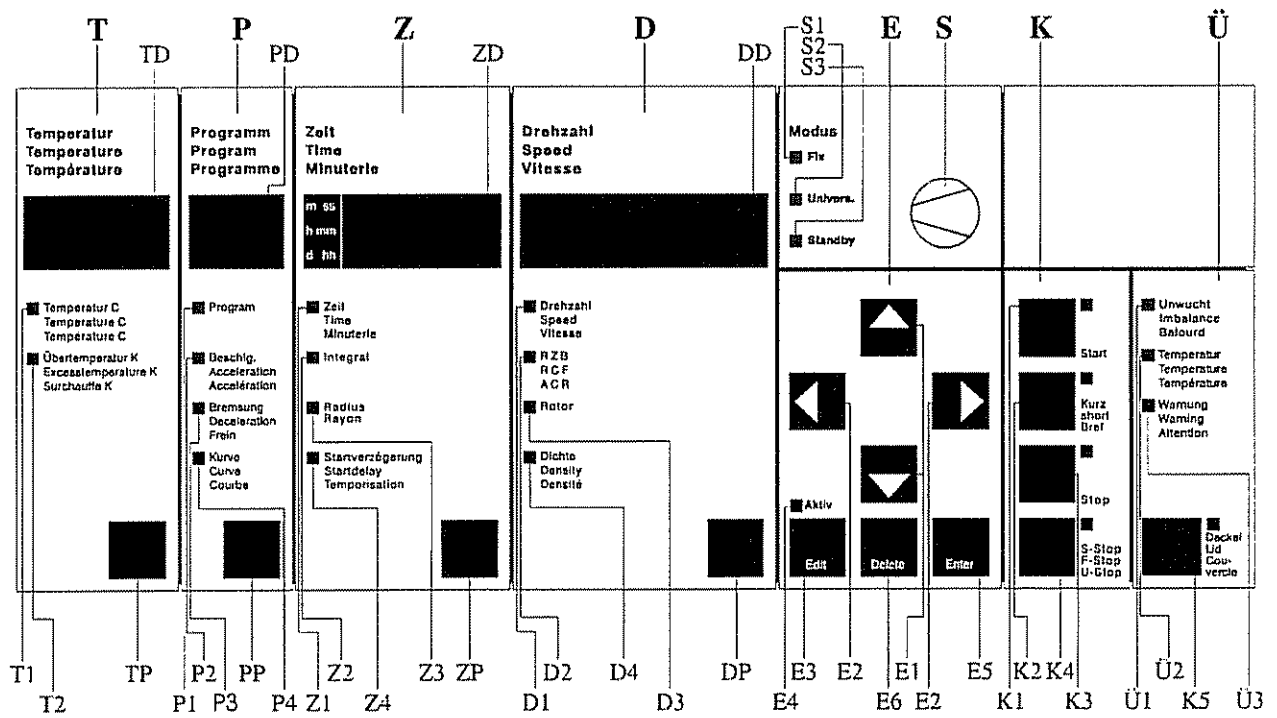

T	Temperature panel	D	Speed panel	Ü	Monitoring panel
TP	Temperature parameter key	DP	Speed parameter key	Ü1	Monitoring-LED imbalance
TD	Temperature display	DD	Speed display	Ü2	Monitoring-LED temperature
T1	Temperature-LED	D1	Speed-LED	Ü3	Monitoring-LED warning
T2	Excess temperature-LED	D2	RCF-LED	K5	Lid-key
P	Program panel	D3	Rotor-LED	E	Input panel
PP	Program parameter key	D4	Density-LED	E1	Alteration keys
PD	Program panel display	E		E2	Cursor keys
P1	Program-LED	E1		E3	Edit-key
P2	Acceleration-LED	E2		E4	Edit-Aktiv-LED
P3	Deceleration-LED	E3		E5	Enter-key
P4	Curve-LED	E4		E6	Delete-key
Z	Time panel	K	Command panel		
ZP	Time parameter key	K1	Start-key		
ZD	Time display	K2	Short-key		
Z1	Time-LED	K3	Stop-key		
Z2	Integral-LED	K4	Faststop-key		
Z3	Radius-LED				
Z4	Start delay-LED				
				S	Key-operated switch
				S1	Fix-Mode-LED
				S2	Universal-Mode-LED
				S3	Standby-Mode-LED