

Refrigerated Centrifuge

8 K 10 OPERATING MANUAL

Dear customer,

Congratulations for purchasing a SIGMA laboratory centrifuge. You have selected a device which combines many advantages.

A wide spectrum of programming options and an electronic operation control allow a trouble-free use of the centrifuge. With its 3-phase drive, maintenance-free quiet operation without any carbon dust pollution is guaranteed.

Your device is equipped with user-friendly options which make the operation and standard settings easier for you. Built-in error-detecting functions keep the user from entering incorrect values and check the complete operation.

A special advantage is the storage capacity the centrifuge offers. The instrument has a large program memory which can store up to 60 different data sets and is also capable of keeping the last run program in its memory for an unlimited amount of time allowing the program to be restarted at any time - even if the centrifuge was turned off in between.

All settings are executed via the control panel the coated surface of which offers a clear arrangement and protects the device against moisture and dust at the same time. In addition, the interior of the centrifuge is also easy to clean. With that we are able to offer you a device that combines functional variety with practical applications.

We thank you for your confidence and wish you a successful application of the centrifuge.

SIGMA Laborzentrifugen GmbH
Postfach 1713 - D-37507 Osterode
Tel. 05522/5007-0 - Telefax 05522/500712

Internet : www.sigma-zentrifugen.de
eMail : info@sigma-zentrifugen.de

Konformitätserklärung
(73/23/EWG; 89/336/EWG; 98/37/EWG)
Statement of Conformity
(73/23/CEE; 89/336/CEE; 98/37/CEE)
Déclaration de conformité
(73/23/CEE; 89/336/CEE; 98/37/CEE)

Die nachfolgend bezeichnete Maschine wurde in Übereinstimmung mit den Richtlinien 73/23/EWG; 89/336/EWG und 98/37/EWG hergestellt und geprüft.

The following machine is manufactured and tested in compliance with directions 73/23/CEE; 89/336/CEE and 98/37/CEE.

La machine désignée ci-dessous est produit et examiné conforme aux directives 73/23/CEE; 89/336/CEE et 98/37/CEE

Bezeichnung der Maschine: Laborzentrifuge
Machine: Laboratory Centrifuge
Désignation de la machine: Centrifugeuse de laboratoire

Maschinentyp : 8 K 10
Type:
Type de la machine:

Bestell Nr. : 10890, 10891, 10892, 10893, 10894,
Part No.: 10895, 10896, 10897
Réf. usine:

Normen: EN 61010-2-020
Standards: EN 61000-3-2 ; EN 61000-3-3
Normes : EN 61326

Sigma Laborzentrifugen
An der Unteren Söse 50
D-37520 Osterode

01.02.2002

Geschäftsführer
Managing Director
Directeur Gérant

Fabr. Nr. Serial No. Numero de fabrication

SHORT INSTRUCTION

for SIGMA 8K 10

with free programming of the operation parameters

Important: Please pay attention to the notes in the detailed operating instructions

1. _____
Level centrifuge on site (3.2.4).

2. _____
Check the name rating plate for the correct voltage and frequency, then plug the power cord into the wall receptacle (3.2).

3. _____
Press the power switch to on (3.4.1) (at the right of the control panel). Close the lid.

4. _____
Turn key-operated switch in the mode display until LED **Univ.** is illuminated (4.3.2).

The following displays are illuminated (basic program, if no program had been stored):

- Speed panel **2000** LED **Speed**
- Time panel **2.00** m ss LED **Time**
- Program panel -- LED **Program**
- Temperature panel **20** LED **Temperature**
- LED Lid
- LED **Start**
- LED **Short**

The run can be started with these parameters, if the rotor is installed and the lid is closed.

4.1 _____
Open the lid, install the rotor according to detailed operating instructions (3.4.2 and 3.4.3) and close the lid.

5. _____
Enter run parameters (3.4 and 4.2):

Press the Edit-key,
LED **Aktiv** is illuminated (4.2).

a) Press the parameter key in the speed panel until LED **Rotor** is illuminated (3.4.4).
Select the rotor number using the alteration keys $\Delta \nabla$.
The rotor number is displayed in the speed panel.
If "buc" is displayed in the time display and LED **Rotor** is flashing, enter bucket number.

b) Press the parameter key in the speed panel until LED **Speed** is illuminated.
The desired speed can be set using the alteration keys $\Delta \nabla$.
The corresponding relative centrifugal field RCF is calculated from rotor number, bucket number and speed.

c) Press the parameter key in the speed panel until LED **RCF** is illuminated.
The relative centrifugal field of the rotor or bucket in use at the set speed is displayed.
Another centrifugal field can be set using the alteration keys $\Delta \nabla$.
The corresponding speed is calculated.

d) Press the parameter key in the speed panel until LED **Density** is illuminated.
Set higher specific gravity of the product. The max. allowed speed is automatically reduced.

e) Press the parameter key in the time panel until LED **Time** is illuminated, the last digit will flash.
Set the desired run time using the alteration keys $\Delta \nabla$. The run time is displayed depending on the set units in minutes/seconds, hours/minutes or days/hours (4.4.2 Time).

f) Press the parameter key in the temperature panel until LED **Temperature** is illuminated.
Set the desired temperature in °C using the alteration keys $\Delta \nabla$.
If a temperature below 0 °C is desired, press the alteration key until the temperature below 0 °C is displayed with "-".

g) Press the parameter key in the temperature panel until LED **Excess temperature K** is illuminated.
Set desired value.

h) Press the parameter key in the program panel until LED **Acceleration** is illuminated.

Select the desired acceleration curve using the alteration keys $\Delta\nabla$ (0 - 19 available).

- i) Press the parameter key in the program panel until LED **Deceleration** is illuminated. Select the desired deceleration curve using the alteration keys $\Delta\nabla$ (0 - 19 available).
- j) Press the parameter key in the program panel until LED **Program** is illuminated. Select desired program number using the alteration keys $\Delta\nabla$ (0 - 59 available.)

Store entered data using the Enter-key.

6. Start the program using the Start-key.

7. Alteration of program (during run; 5.6):

- a) Press the Edit-key.
- b) Select required panel using the parameter key. The parameter to be changed will flash.
- c) Change the value using the alteration keys $\Delta\nabla$.
- d) The changed parameters are used for the actual run by pressing the Enter-key.

8. The run can be stopped at any time by pressing the Stop or Faststop-key.

Control Panel

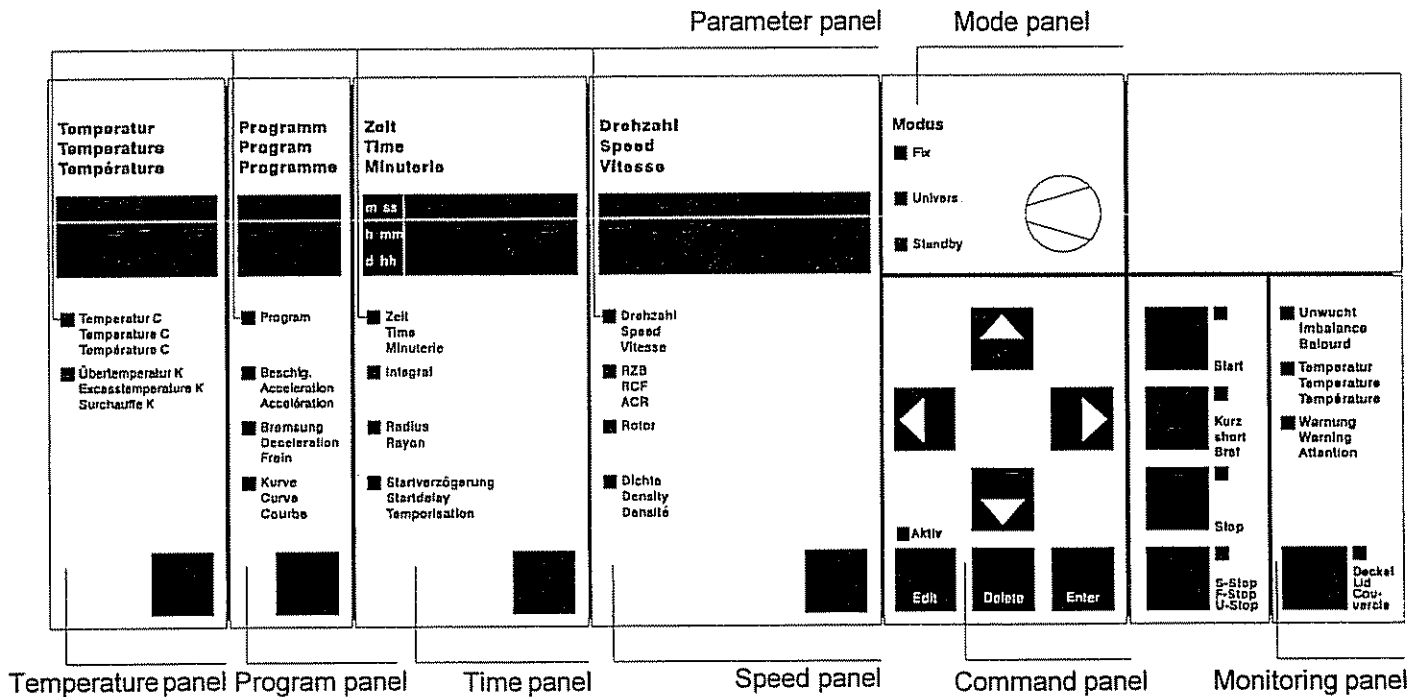

(Subject to technical alterations)

Table of Contents:

1. General Information

- 1.1 Technical data
- 1.2 Suitable accessories
- 1.3 Scope of supply
- 1.4 Standards and regulations
- 1.5 Safety instructions
- 1.6 Symbol table

2. Description of the Centrifuge

- 2.1 General outlay
- 2.2 Construction and constructive safety measures
- 2.3 Drive
- 2.4 Data input and output
- 2.5 Electronics
- 2.6 Safety devices
 - 2.6.1 Lid lock, cover closing device
 - 2.6.2 Imbalance monitoring system
 - 2.6.3 Excess temperature in the centrifuge chamber
 - 2.6.4 Rotor monitoring
 - 2.6.5 Standstill monitoring
 - 2.6.6 System check
 - 2.6.7 Earth wire check

3. Installation and Start-up

- 3.1 Unpacking of the centrifuge
 - 3.1.1 Transport safety device/transport conditions
- 3.2 Installation
 - 3.2.1 Site
 - 3.2.2 Connection
 - 3.2.3 Fuses / emergency circuit breaker on site
 - 3.2.4 Leveling on site
- 3.3 Insertion of rotors and accessories
- 3.4 Initial start-up
 - 3.4.1 Switching on of the centrifuge
 - 3.4.2 Opening lid
 - 3.4.3 Insertion of rotor
 - 3.4.4 Selecting a rotor or bucket number
 - 3.4.5 Starting and stopping a run

Table of Contents:

4. Operating Elements

- 4.1 Operating panel
- 4.2 Displays and keys
- 4.3 Control panels
 - 4.3.1 Command panel (K)
 - 4.3.2 Key-operated switch (S)
- 4.4 Display panels
 - 4.4.1 Speed panel (D)
 - 4.4.2 Time panel (Z)
 - 4.4.3 Temperature panel (T)
 - 4.4.4 Program panel (P)
 - 4.4.5 Monitoring panel (Ü)

5. Programming

- 5.1 Selection, display and alteration of program parameters
- 5.2 Loading a program (calling up a saved program)
- 5.3 Changing and saving a program
- 5.4 Deleting a program
- 5.5 Changing a program during centrifuge operation
- 5.6 Programming the relative centrifugal force, density and integral
 - 5.6.1 Specifying a relative centrifugal force (RCF)
 - 5.6.2 Specifying a density
 - 5.6.3 Specifying an integral
- 5.7 Programming variable acceleration and deceleration curves
 - 5.7.1 Deleting intervals
 - 5.7.2 Changing a programmed curve
 - 5.7.3 Example: Specifying a program with a freely programmable curve
- 5.8 Pre-cooling

6. Notes for Centrifugation

- 6.1.1 Practical notes for centrifugation
- 6.1.2 Important notes for the centrifugation of blood bag systems
- 6.2 Forbidden centrifuging operations

7. Care and Maintenance

- 7.1 Care and cleaning of centrifuge
- 7.2 Care and cleaning of accessories
- 7.3 Rotor pins
- 7.4 Glass breakage
- 7.5 Care and cleaning of the condenser
- 7.6 Sterilization and disinfection of rotor chamber and accessories
 - 7.6.1 Autoclaving
- 7.7 Checks by operator

Table of Contents:

8. Appendix

- 8.1 Slope of the specified curves, linear curves
- 8.2 Quadratic curves
- 8.3 Entry limitations
- 8.4 Mathematical relation
 - 8.4.1 Relative Centrifugal Force (RCF)
 - 8.4.2 Density
 - 8.4.3 Integral
- 8.5 Error correction
 - 8.5.1 Centrifuge cannot be started
 - 8.5.2 Centrifuge decelerates during operation
 - 8.5.3 Lid cannot be opened/closed
 - 8.5.4 Emergency lid release
 - 8.5.5 Problems with the centrifuge?
- 8.6 Error codes
- 8.7 Diagram speed/gravitational field
- 8.8 Declaration of decontamination/Return declaration
- 8.9 Form program data
- 8.10 Form curve data
- 8.11 Leaflet

1. General Information:

1.1 Technical Data	
Manufacturer:	S I G M A Laborzentrifugen GmbH 37520 Osterode
Type:	8K 10
Electr. connection: Protection class:	3 x 400 V, 50 Hz I
Power consumption (kVA): Rated power (kW): Max. current consumption (A):	7,5 6,5 11,5
Power data:	
Max. speed (rpm): Max. capacity (l): Max. gravitational field(x g): Max. kin. energy (Nm):	10 500 12 20 954 236 000
Further parameters	
Time range: Temperature setting range: Excess temperature: Programs: Acceleration curves: Deceleration curves: Integral: Radius: Rotor and bucket part no.:	9 min, 59 sec 9 h, 59 min 9 days, 23 h -10 to +40 °C 5 to 50 Kelvin 60 10 linear 10 quadratic 10 freely programmable 9 linear 1 brakeless 10 quadratic 10 freely programmable 9999 Exp. 11 Swedberg max./min. s. chapter 1.2 s. chapter 1.2
Dimensions: Depth (mm): Width (mm): Height (mm): Weight (kg): EMC (according to EN 55011): Noise level (dBA):	930 810 1080 450 Class B < 70 (at max. speed) < 63 (during pre-cooling)
Notes of user: Serial number: Supply date: Inventory number: Location: Responsibility:	

The figures are valid for an ambient temperature of +23 °C +/- 2 °C and 3 x 400 Volt +/- 5 %
The minimum temperatures achieved during run are < +4 °C and depend on type of rotor, speed
and ambient temperature. (Allowable ambient temperature +10 °C - +35 °C; max. humidity of air
80 %) Subject to technical alterations

1. General Information:

1.2 Accessories Suitable for SIGMA 8K10

Part No.	Description	Max. speed (rpm)	Max. gravitational field (x g)
11800	Swing-out rotor with windshield for 6 buckets 13800, 13801, 13810, 13815, 13820, 13821	5 130	
	Speeds and gravitational fields:		
	13800 max. radius 28.7 cm, min. radius 14.5 cm,	4 070	5 315
	13801 max. radius 27.7 cm, min. radius 13.0 cm,	5 130	9 150
	13810 max. radius 28.9 cm, min. radius 13.0 cm,	5 130	8 503
	13815 max. radius 28.9 cm, min. radius 15.5 cm,	1 500	727
	13820 max. radius 23.8 cm, min. radius 15.0 cm,	5 130	7 003
	13821 max. radius 23.8 cm, min. radius 15.0 cm	4 600	5 630
11801	Swing-out rotor for 6 buckets 13800, 13801, 13810, 13815, 13820, 13821, 13822	3 700	
	Speeds and gravitational fields:		
	13800 max. radius 28.7 cm, min. radius 14.5 cm	3 700	4 393
	13801 max. radius 27.7 cm, min. radius 13.0 cm	3 700	4 240
	13810 max. radius 28.9 cm, min. radius 13.0 cm	3 700	4 423
	13815 max. radius 28.9 cm, min. radius 15.5 cm	1 500	727
	13820 max. radius 23.8 cm, min. radius 15.0 cm	3 700	3 643
	13821 max. radius 23.8 cm, min. radius 15.0 cm	3 700	3 643
	13822 max. radius 28.9 cm, min. radius 13.7 cm	3 300	3 519
13800	Double bucket , aluminium, for 2 blood bag systems 1 - 4 fold		
13805	Plastic adapter for standard blood bag 500 - 600 ml, 6 pcs., suitable for 13800		

1. General Information:

Part No.	Description	Max. speed (rpm)	Max. gravitational field (x g)
13806	Plastic adapter for blood bag approx. 300 – 400 ml, 6 pcs., suitable for 13800		
13801	Double bucket, aluminium, incl. plastic adapter 13803, for 2 blood bag systems, e.g. Baxter 5-fold bags		
13815	Thrombocyte bucket, max. capacity 2 x 150 ml, 2 bag systems per bucket, max. bag length 160 mm, complete with collecting vessel		
13822	Double bucket, aluminium, for 2 tubes 1000 ml, e.g. 13823 and for the system of round carriers \varnothing 100 mm 17650 up to 17699, suitable for 11801 only		
13810	Round bucket, aluminium, sealable with cap 17110, suitable for the system of round carriers \varnothing 100 mm 17650 up to 17699, for 1 stainless steel bottle 1000 ml 13510 and stainless steel bush for bottles 15920, 15921		
17110	Sealing cap, polycarbonate, for 13810, clear, for tubes max. \varnothing 100 x 160 mm		
13511	Stainless steel bush \varnothing 100 x 152 mm, for tubes 15911, 15912, 15920, 15921, sealable with cap 17911, suitable for 12510, 13810, 13822		
17911	Sealing cap for 13511		
15920	Polycarbonate bottle with screw cap 1000 ml, \varnothing 97 x 175 mm, suitable for 13810 and 12510 with 13511		
15921	ditto, polypropylene		
13510	Stainless steel bottle 1000 ml, \varnothing 100 x 167 mm (170 mm incl. cap), incl. sealing cap 17520, suitable for 13810 and 12510,		

1. General Information:

Part No.	Description	Max. speed (rpm)	Max. gravitational field (x g)
17520	Stainless steel sealing cap for 13510		
13823	Polypropylene tube 1000 ml, Ø 100 x 150 mm, sealable with cap 17123, suitable for 13822		
17123	Sealing cap, polypropylene, for 13823		
13811	Adapter for 1 bottle 500 ml 13507, 15508, 15509, suitable for 13810		
15508	Polypropylene bottle with screw cap 500 ml, Ø 69 x 165 mm, suitable for 13810 with 13811, 12505		
15509	ditto, polycarbonate		
13507	Stainless steel bottle 500 ml, Ø 69.5 x 152 mm, sealable with cap 17256, suitable for 13810 with 13811, 13822 with 13655, 12505		
17256	Stainless steel sealing cap for 13507		

Adapters for buckets 13810 and 13822

17651	Round carrier for 20 blood sample tubes with flat bottom, max. Ø 15.5/18 x 50 - 75 mm, e.g. Monovettes 4.5 ml or Primavettes, polypropylene
17652	Round carrier for 36 RIA-tubes 5 ml, max. Ø 12.5 x 65 - 80 mm, e.g. 15060, polypropylene
17653	Round carrier for 26 reaction vials 1.5-2.2 ml, max. Ø 11 mm, e.g. 15008, 15040, polypropylene
17654	Round carrier for 32 glass tubes 7 ml, max. Ø 12.5 x 85 - 115 mm, e.g. 15007, 15027, polypropylene

1. General Information:

Part No.	Description	Max. speed (rpm)	Max. gravitational field (x g)
17655	Round carrier for 20 tubes with screw cap 10-12 ml, max. Ø 16.2/18 x 65 - 90 mm, e.g. 13026 plus 17126, 15000, 15010, 15039, polypropylene		
17656	Round carrier for 22 blood sample tubes 5-6 ml, max. Ø 13.5/17.5 x 70 - 90 mm, e.g. 15060, Vacutainer/hemolyse/RIA tubes, polypropylene		
17658	Round carrier for 19 tubes 9-15 ml, max. Ø 17.2/19.5 x 85 - 115 mm, e.g. 15015, 15020, 15022, 15023, 15024 and Monovettes 9 ml and 10 ml, polypropylene		
17659	Round carrier for 12 culture tubes 15 ml (Nunc, Falcon, Corning, Greiner) with cap max. Ø 23 mm, e.g. 15115, polypropylene		
17660	Round carrier for 15 culture tubes 15 ml (Nunc, Falcon, Corning, Greiner) with cap max. Ø 22 mm, e.g. 15115, polypropylene		
17670	Round carrier for 8 tubes 25-30 ml, max. Ø 25.4/30 x 90 - 115 mm, e.g. 15025, 15026, 15029, 15030, 15032, 15033, polypropylene		
17675	Round carrier for 4 tubes 50 ml, max. Ø 35/38 - 90 - 115 mm, e.g. 15049, 15050, 15056, polypropylene		
17676	Round carrier for 7 tubes with screw cap 40-50 ml, max. Ø 29/32 x 90 - 115 mm, e.g.13055 plus 17054, 15051, 15052, 15054, polypropylene		
17677	Round carrier for 5 culture tubes 50 ml (Nunc, Falcon, Corning, Greiner), e.g. 15151, polypropylene		
17678	Round carrier for 3 tubes with screw cap 78-85 ml, max. Ø 38/40 x 90 - 115 mm, e.g. 13085 plus 17185, 15074, 15075, 15076, 15080, polypropylene		

1. General Information:

Part No.	Description	Max. speed (rpm)	Max. gravitational field (x g)
17690	Round carrier incl. rubber cushion 16051 for 2 tubes 100 ml, max. Ø 45/47 x 85 - 110 mm, e.g. 15100, 15102, 15103, 15106, polypropylene		
17692	Round carrier for 1 bottle with screw cap 125 ml, max. Ø 51 x 90 - 115 mm, e.g. 15125, polypropylene		
17694	Round carrier for 1 pointed bottom bottle 150-250 ml, max. Ø 61.5 x 120 - 140 mm, e.g. 15175, polypropylene		
17695	Round carrier incl. rubber cushion 16250 for 1 tube 175-250 ml, max. Ø 57.5 x 90 - 137 mm, e.g. 15201, 15206, 15250, 15251, 15254, polypropylene		
17696	Round carrier for 1 bottle with screw cap 200 ml, max. Ø 57 x 90 - 115 mm, e.g. 15202, 15203, polypropylene		
17698	Round carrier for 1 bottle with screw cap 250 ml, max. Ø 61.5 x 90 - 125 mm, e.g. 13255, 15247, 15248, polypropylene		
17682	Round carrier for 1 pointed bottom bottle with screw cap 500 ml, Ø 96 x 150 mm, Corning 432123, polypropylene		
13655	Adapter for 1 bottle with screw cap 500 ml, max. Ø 69.5 x 165 mm, e.g. 13507 with 17256, 15508, 15509, polypropylene		
13820	Double rectangular bucket, aluminium, for 2 rectangular carriers		
17114	Sealing cap, polysulfone, for 13820		
13821	Threefold bucket, aluminium, for 3 rectangular carriers		
18000	Rectangular carrier, undrilled, for tubes 85 - 110 mm long, polyallomer		

1. General Information:

Part No.	Description	Max. speed (rpm)	Max. gravitational field (x g)
18002	Rectangular carrier for 20 reaction vials 1.5-2.2 ml, max. \varnothing 11 mm, e.g. 15008, 15040, polypropylene		
18003	Upper part for 18002 for 20 reaction vials 1.5-2.2 ml, max. \varnothing 11 mm, e.g. 15008, 15040 (can be used together with 18002), polypropylene		
18005	Rectangular carrier for 20 RIA-tubes 5 ml, max. \varnothing 12.2 x 60 - 75 mm, flat and round bottom, e.g. 15060, polyallomer		
18007	Rectangular carrier for 20 glass tubes 7 ml, max. \varnothing 12.3 x 80 - 105 mm, flat and round bottom, e.g. 15007, 15027, polyallomer		
18009	Rectangular carrier for 20 hemolyse tubes, max. \varnothing 12.8 x 70 - 90 mm, polypropylene		
18010	Rectangular carrier for 12 tubes with screw cap 10-12 ml, max. \varnothing 16.8/17.5 x 60 - 85 mm, e.g. 13026 plus 17126, 15000, 15010, 15039, polyallomer		
18012	Rectangular carrier for 12 Vacutainer-tubes \varnothing 13.5/18 x 65 - 90 mm, polypropylene		
18015	Rectangular carrier for 12 tubes 10-15 ml, max. \varnothing 17 x 90 - 105 mm, e.g. 15015, 15020, 15022, 15023, 15024, polyallomer		
18016	Rectangular carrier for 4 culture tubes 15 ml (Nunc, Falcon, Corning, Greiner), e.g. 15115, polypropylene		
18017	Rectangular carrier for 10 tubes 15 ml and tubes with cap, max. \varnothing 17.2/18 x 80 - 112 mm, e.g. Monovettes 9 ml and 10 ml, polypropylene		
18025	Rectangular carrier for 5 glass tubes 25 ml, max. \varnothing 24 x 85 - 105 mm, e.g. 15025, 15026, polyallomer		

1. General Information:

Part No.	Description	Max. speed (rpm)	Max. gravitational field (x g)
18022	Rectangular carrier for 4 sterilin tubes 30 ml, graduated up to 20 ml, with skirt, incl. cap, max. \varnothing 25/31 x 65 - 95 mm, polypropylene, see www.bibby-sterilin.co.uk , no. 03008		
18030	Rectangular carrier for 5 tubes with screw cap 27-30 ml, max. \varnothing 25.4/27.5 x 80 - 110 mm, e.g. 15029, 15030, 15032, polypropylene		
18050	Rectangular carrier for 2 tubes 50 ml, max. \varnothing 35/38 x 85 - 110 mm, e.g. 15049, 15050, 15056, polyallomer		
18051	Rectangular carrier for 2 tubes with screw cap 40-50 ml, max. \varnothing 29/35 x 80 - 110 mm, e.g. 13055 plus 17054, 15051, 15052, 15054, polypropylene		
18052	Rectangular carrier for 2 culture tubes 50 ml (Nunc, Falcon, Corning, Greiner), e.g. 15151, polypropylene		
18053	Rectangular carrier for 2 culture tubes 50 ml with skirt (Nunc, Falcon, Corning, Greiner), max. \varnothing 29.5/38 x 85 - 118 mm, polypropylene		
18085	Rectangular carrier for 1 tube with screw cap 78-85 ml, max. \varnothing 38/40 x 85 - 112 mm, e.g. 13085 plus 17185, 15074, 15075, 15076, 15080, polyallomer		
18100	Rectangular carrier for 1 tube 100 ml, max. \varnothing 45.5/48 x 85 - 110 mm, e.g. 15100, 15102, 15103, 15106, polyallomer		
18105	Rectangular carrier for 20 RIA-tubes 5 ml, max. \varnothing 12.2 x 60 - 75 mm, flat and round bottom, e.g. 15060, decantable, polyallomer		

1. General Information:

Part No.	Description	Max. speed (rpm)	Max. gravitational field (x g)
18107	Rectangular carrier for 20 glass tubes 7 ml, max. \varnothing 12.3 x 80 - 105 mm, flat and round bottom, e.g. 15007, 15027, decantable, polyallomer		
18115	Rectangular carrier for 12 tubes 10-15 ml, max. \varnothing 17 x 90 - 105 mm, e.g. 15015, 15020, 15022, 15023, 15024, decantable, polyallomer		
18125	Rectangular carrier for 1 bottle with screw cap 125 ml, max. \varnothing 51 x 90 - 115 mm, e.g. 15125, polypropylene		
18200	Rectangular carrier for 1 bottle with screw cap 200 ml, max. \varnothing 57 x 90 - 115 mm, e.g. 15202, 15203, polypropylene		
18250	Rectangular carrier incl. rubber cushion 16051 for 1 tube 175-250 ml, max. \varnothing 56.5 x 90 - 137 mm, e.g. 15201, 15206, 15250, 15251, 15254, suitable without sealing cap 17114, polypropylene		
18251	Rectangular carrier for 1 bottle 250 ml, max. \varnothing 61.5 x 90 - 125 mm, e.g. 15247, 15248, 15249, stainless steel bottle 13255, suitable without sealing cap 17114, polypropylene		
18815	Rectangular carrier for 22 culture tubes 15 ml (Nunc, Falcon, Corning, Greiner), e.g. 15115, for 13821 only, polypropylene		
18850	Rectangular carrier for 8 culture tubes 50 ml (Nunc, Falcon, Corning, Greiner), e.g. 15151, for 13821 only, polypropylene		
12510	Angle rotor 6 x 1000 ml, incl. steel bushes 13511, for bottles e.g. 13510, 15920, 15921, max. radius 20.6 cm, min. radius 5.5 cm, angle 25°	7 000	11 285
15920	Polycarbonate bottle with screw cap 1000 ml, \varnothing 97 x 175 mm, suitable for 12150 and 13810 with 13511		

1. General Information:

Part No.	Description	Max. speed (rpm)	Max. gravitational field (x g)
15921	ditto, polypropylene		
13510	Stainless steel bottle 1000 ml, \varnothing 100 x 167 mm (170 mm incl. cap), incl. sealing cap 17520, suitable for 12510 and 13810		
17520	Stainless steel sealing cap for 13510		
12505	Angle rotor 6 x 500 ml, for bottles e.g. 13507, 15508, 15509, max. radius 16.6 cm, min. radius 4.1 cm, angle 30°	10 500	20 461
15508	Polypropylene bottle 500 ml incl. screw cap, \varnothing 69 x 165 mm, suitable for 12505, 13655 13811		
15509	ditto, polycarbonate		
13507	Stainless steel bottle 500 ml, \varnothing 69.5 x 152 mm, suitable for 12505, 13811		
17507	Stainless steel sealing cap for 13507		
12258	Angle rotor 8 x 250 ml, for bottles e.g. 13255, 15247, 15247, 15249, max. radius 17.0 cm, min. radius 6.4 cm, angle 30°	10 500	20 945
15247	Teflon bottle 250 ml incl. screw cap, \varnothing 61.4 x 122 mm, suitable for 12258		
15248	Polycarbonate bottle 250 ml incl. screw cap, \varnothing 61.4 x 125 mm, suitable for 12258		
15249	ditto, polypropylene		
12202	Angle rotor 100 x 1.5-2.2 ml for reaction vials, e.g. 15008, 15040, 2 lines, max. radii 16.5/15.2 cm, min. radii 13.3/12.0 cm, angle 45°	10 500	20 338/18 735

Adapters, plastic vessels and steel tubes

13000	Adapter , POM, for reaction vials 0.25-0.4 ml 15014, suitable for 12202, 17653, 18002, 18003
-------	--

1. General Information:

Part No.	Description
13002	Adapter, POM, for reaction vials 0.5-0.75 ml, 15005, Ø 7.9/10 x 28/31 mm suitable for 12202, 17653, 18002, 18003
13021	Adapter for PCR-tube 0.2 ml, Ø 5.85/6.95 x 20/23.4 mm, suitable for 12202, 17653, 18002, 18003
15005	Reaction vials 0.5 ml, Ø 7.9/10 x 28/31 mm, 1 pack contains 100 pcs., suitable for 13002
15008	Reaction vials 1.5 ml, 1 pack contains 100 pcs., suitable for 12202, 17653, 18002, 18003
15040	Reaction vials 2.2 ml, 1 pack contains 100 pcs., suitable for 12202, 17653, 18002, 18003
15014	Reaction vials 0.4 ml (Beckman system), polypropylene, 1 pack contains 100 pcs., suitable for 13000
15060	Polystyrene tube 5 ml (RIA-tube), Ø 12 x 75 mm, suitable for 17652, 17656, 18005, 18009, 18105
13026	Stainless steel tube 10 ml, Ø 15.7 x 76 mm, sealable with cap 17126, suitable for 17655, 18010
17126	Stainless steel sealing cap for 13026
15000	Teflon tube with screw cap 12 ml, Ø 16.1 x 81.1 mm, suitable for 17655, 18010
15010	ditto, polycarbonat
15039	ditto, polypropylene
15020	Polystyrene tube 15 ml, Ø 17 x 100 mm, suitable for 17658, 18015, 18115
15021	Polypropylene stopper for 15020, 15023

1. General Information:

Part No.	Description
15023	Polypropylene tube 15 ml, Ø 17 x 100 mm, suitable for 17658, 18015, 18115
15115	Culture tube with screw cap 15 ml, pointed bottom, polypropylene, suitable for 17659, 17660, 18016, 18115
15029	Teflon tube with screw cap 28 ml, Ø 25.3 x 96 mm, suitable for 17670, 18030
15030	Polycarbonate tube with screw cap 30 ml, Ø 25.3 x 98 mm, suitable for 17670, 18030
15032	Polypropylene tube with screw cap 27 ml, Ø 25.3 x 97 mm, suitable for 17670, 18030
15049	Polycarbonate tube 50 ml, Ø 34 x 100 mm, graduated 0 - 50 ml in steps of 1 ml, suitable for 17675, 18050
13055	Stainless steel tube 50 ml, sealable with cap 17054, Ø 29 x 101.5 mm, suitable for 17676, 18051
17054	Stainless steel sealing cap for 13055
15051	Teflon tube with screw cap 42 ml, Ø 28.5 x 107 mm, suitable for 17676, 18051
15052	Polypropylene tube with screw cap 42 ml, Ø 28.8 x 107 mm, suitable for 17676, 18051
15054	Polycarbonate tube with screw cap 40 ml, Ø 28.8 x 107 mm, suitable for 17676, 18051
15151	Culture tube with screw cap 50 ml, pointed bottom, polypropylene, suitable for 17677, 18052, 18850
13085	Stainless steel tube 85 ml, sealable with cap 17185, Ø 38/40 x 100/107 mm, suitable for 17678, 18085
17185	Stainless steel sealing cap for 13085

1. General Information:

Part No.	Description
15074	Polycarbonate tube with screw cap made of aluminium for high speeds 72 ml, Ø 38 x 109 mm, suitable for 17678, 18085
15075	Polycarbonate tube with screw cap 82 ml, Ø 38 x 112 mm, suitable for 17678, 18085
15076	Polypropylene tube with screw cap 78 ml, Ø 38 x 112 mm, suitable for 17678, 18085
15080	Polyflor tube with screw cap 81 ml, Ø 38 x 112 mm, suitable for 17678, 18085
15102	Polypropylene tube 100 ml, Ø 45 x 100 mm, suitable for 17690, 18100
15103	ditto, polycarbonate, graduated 2 - 100 ml in steps of 2 ml
15125	Polypropylene tube with screw cap 125 ml, Ø 51 x 99 mm, suitable for 17692, 18125
15175	Polypropylene bottle with pointed bottom 200 ml, Ø 61.5 x 139 mm, graduated up to 175 ml (N-3143-0175), suitable for 13175 with 13175
13174	Adapter for 15175 with 13175, suitable for 12505, 13810 with 13811
13175	Special adapter for 1 bottle 200 ml with pointed bottom 15175, suitable for 13174
15202	Polypropylene bottle with screw cap 190 ml, Ø 56 x 112 mm, suitable for 17696, 18200
15203	Polycarbonate bottle with screw cap 200 ml, Ø 56 x 113 mm, suitable for 17696, 18200
13255	Stainless steel bottle 250 ml, sealable with cap 17256, Ø 61.4 x 125 mm, suitable for 12258, 17698, 18251
17256	Stainless steel sealing cap for 13255

1. General Information:

Part No.	Description
15247	Teflon bottle with screw cap 250 ml, Ø 61.4 x 122 mm, suitable for 12258, 17698, 18251
15248	Polycarbonate bottle with screw cap 250 ml, Ø 61.4 x 125 mm, suitable for 12258, 17698, 18251
15249	ditto, polypropylene
15251	Polypropylene tube 250 ml, Ø 57 x 135 mm, suitable for 17695, 18250
15508	Polypropylene bottle with screw cap 500 ml, Ø 69 x 165 mm, suitable for 12505, 13655, 13810 with 13811
15509	ditto, polycarbonate

Glass tubes

15007	Glass tube 7 ml, Ø 12 x 100 mm, suitable for 17654, 18007, 18107
15027	ditto, graduated 0 - 5.5 ml in steps of 0.1 ml
15015	Glass tube 10-12 ml, Ø 16 x 100 mm, suitable for 17658, 18015, 18115
15024	ditto, graduated 0 - 10 ml in steps of 0.1 ml
15025	Glass tube 25 ml, Ø 24 x 100 mm, suitable for 17670, 18025
15026	ditto, graduated 5 - 25 ml in steps of 1 ml
15050	Glass tube 50 ml, Ø 34 x 100 ml, suitable for 17675, 18050
15056	ditto, graduated 4 - 50 ml in steps of 1 ml
15100	Glass tube 100 ml, Ø 44 x 100 mm, suitable for 17690, 18100
15106	ditto, graduated 1 - 100 ml in steps of 1 ml

1. General Information:

Part No.	Description
15250	Glass tube 230 ml, Ø 56 x 135 mm, suitable for 17695, 18250
15254	ditto, graduated 15 - 200 ml in steps of 5 ml
15911	Glass tube 800 ml, Ø approx. 95 x 160 mm, suitable for 13810 with rubber cushion 16901 and bush 13511
15912	ditto, graduated 80 - 800 ml in steps of 20 ml
16901	Rubber cushion for glass tube 15911, 15912, suitable for 13810 with bush 13511

Attention, risk of breakage

Please note that especially for the 250, 500 and 1000 ml bottles there is an increased risk of breakage at higher speeds exceeding 7 000 rpm. The supplied supporting rings must always be used. Glass tubes can break at speeds exceeding 3 000 rpm.

Maximum speed for tubes

Some tubes, e.g. centrifuges glass tubes, microtubes, culture tubes, Teflon tubes and especially high volume tubes can be used in our rotors, buckets and adapters at higher speeds than their breaking limit. We recommend to always fill up the tubes and to follow the recommendations of the manufacturer.

1. General Information:

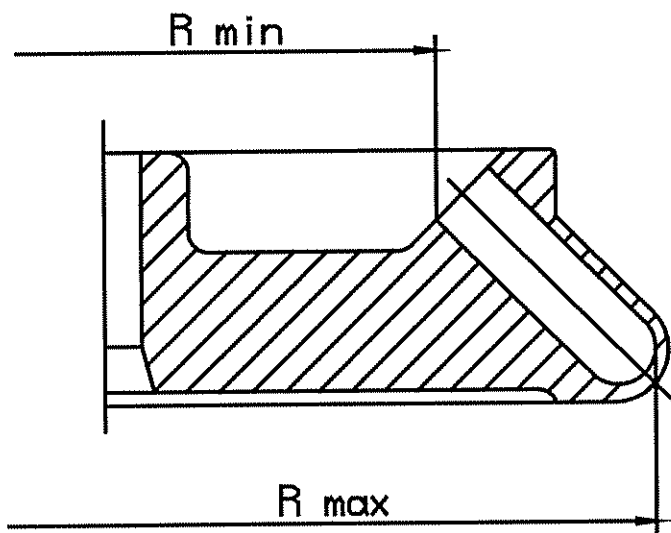
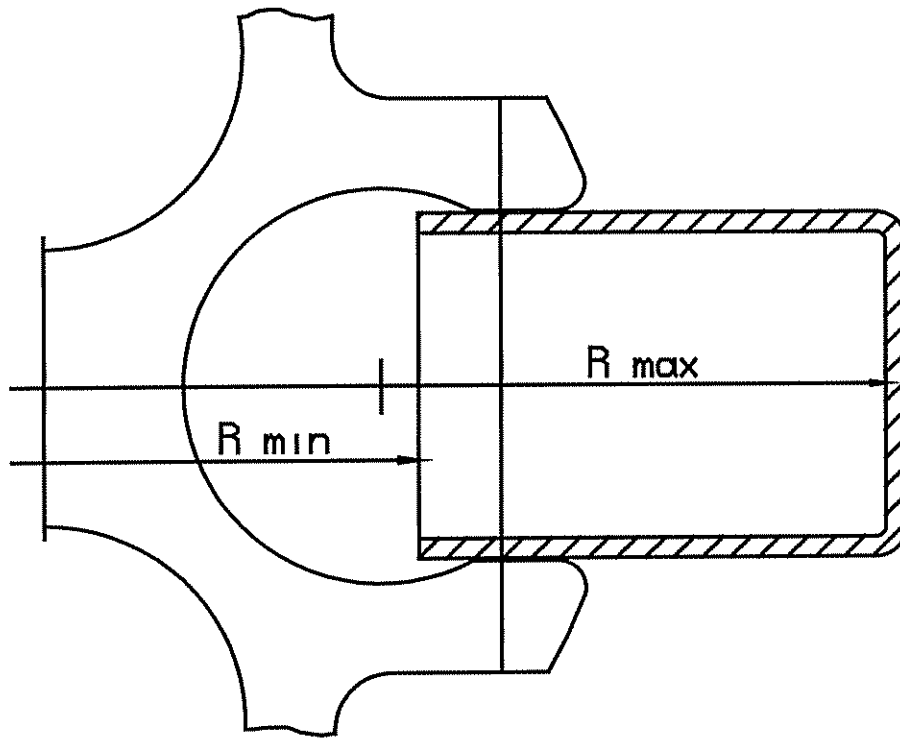

1. General Information:

1.3 Scope of Supply

The following belongs to the centrifuge:

1 Spanner for condensate discharge	Part No. 23 539
1 Emergency lid lock release key	Part No. 23 586
1 Drip cup (condensate discharge)	Part No. 982 505
3 Fuses 16 AT	Part No. 270 016
1 Rotor spanner SW 19	Part No. 930 019
1 Wrench SW 24 (castors)	Part No. 930 024
1 Rotor spanner (hexagon socket SW 4)	Part No. 930 050
1 Tube grease for rotor trunnion pins	Part No. 70 284
20 ml slushing oil	Part No. 70 104

Documentation:

- 1 Short operating instructions
- 1 Operating instructions
- 1 "Rotor and Accessories, Operation and Use"
- 1 EU-Statement of Conformity
- 1 Equipment Decontamination Certificate

Accessories according to your order, our order confirmation and our delivery note.

Rotor Part No.

Rotor No.

.....

.....

.....

.....

.....

.....

.....

.....

.....

.....

.....

.....

.....

.....

1. General Information:

1.4 Standards and Regulations

Please refer to the enclosed EU-Statement of Conformity.

1. General Information:

1.5 Safety Instructions

regarding operation of centrifuges with rotors of different max. speed, eg. angle rotors and swing-out rotors.











According to the German trade association regulation BGR500 chapter 2.11 part 3 the owner of the instrument is advised to take care of the following points:

1. According to BGR500 the owner has to provide operating instructions based on those of the manufacturer and to inform the employees accordingly.
2. For safety reasons these operating instructions must clearly state that the stamped max. speed of the used rotor/bucket and the max. allowable filling quantity must not be exceeded.
3. If the density of the material exceeds 1.2 g/cm^3 , the max. speed of the centrifuge must be reduced respectively the instrument's control electronics automatically reduces the selected speed when a density of higher than 1.2 g/cm^3 is entered.
4. Operation of the centrifuge in hazardous locations is not allowed.
5. During operation the centrifuge must not be moved. Leaning against or resting on the centrifuge is not allowed.
6. Do not spin explosive or highly inflammable materials.
7. Substances which could damage the material of the centrifuge, the rotors or the buckets anyhow must not be centrifuged or only under consideration of special safety measures. Infectious, toxic, pathogene or radioactive substances must be centrifuged in certified rotors only.
8. Keep a clearance of at least 30 cm around the centrifuge. Dangerous materials of any kind must not be put down or stored in that area.
9. Attention!
Defective lid relieving devices could cause the centrifuge lid to fall down (contact Service). Risk of bruising!

1. General Information:

1.6 Symbol Table

International symbols used for the centrifuge:

Symbol	Title
	Gefährliche elektrische Spannung Dangerous voltage Courant haute tension
	Achtung, Bedienungsanleitung beachten Attention, consult accompanying documents Attention, consulter les documents joints
	Ein (Netzverbindung) On (Power) Marche (mise sous tension)
	Aus (Netzverbindung) Off (Power) Arrêt (mise hors tension)
	Schutzleiteranschluß Protective earth (ground) Liaison à la terre
	Erde Earth (ground) Terre
	Netzstecker ziehen Unplug mains plug Tirer la fiche de prise
	Vorsicht Quetschgefahr Caution! Risk of bruising Attention! Danger de blessure
	Drehrichtungspfeil Arrow direction of rotation Flèche sens de rotation
	Heiße Oberfläche Hot surface Surface chaude

2. Description of Centrifuge:

2.1 General Outlay

The new generation of SIGMA laboratory centrifuges is equipped with newest state-of-the-art electronics and is driven by brushless, silent and long-life asynchronous motors.

The problem of carbon brush change is no longer existent and as there is no carbon dust pollution, operation in clean rooms is possible if the appropriate accessories are used.

2.2 Construction and Constructive Safety Measures

The centrifuge is built into a solid steel housing. A new type of cover closing mechanism with eight motorized steel bars provides optimum safety in the event of an accident. The centrifuge lid is also made of solid sheet steel and insulated with synthetic parts which provide the necessary thermal protection. From the back the lid is secured by a solid hinge and at the front by two motorized cover locks.

The bottom of the barrier ring is a one-piece steel plate so that there is a solid safety case around the rotor chamber. The centrifuge stands on castors. There are additional catches to relief the castors and for fixing the centrifuge on site (refer to point 3.2.4 "Leveling on site").

2.3 Drive

The drive motor is a well dimensioned asynchronous motor.

As there are no commutators, no carbon brush change is necessary, there is no carbon dust pollution and the noise level is low.

2.4 Data Input and Output

The input and output unit is a hermetically sealed foil keyboard with clearly distinct keys. Easily readable displays and LED's are available and lead the operator through the wide range of applications.

Option:

A connection for a serial interface is possible so that an external personal computer with printer can be connected for control or recording.

2. Description of Centrifuge:

2.5 Electronics

The electronics controlled by three microprocessors allows extensive adaptations of the centrifuge to the different tasks. The following parameters can be programmed and called among others:

- Speed in steps of 1 rpm
- RCF in steps of 1 x g
- Input of centrifugal radii
- Input and measurement of integral
- Time operation: a) 9 min, 59 sec
 b) 9 h, 59 min
 c) 9 days, 23 h
- Short-time operation
- Operation with preselected start time
- Temperature setting range between -10 °C and +40 °C
- Excess temperatures between 5 and 50 Kelvin
- Fixed deceleration and acceleration curves
- Free programming of deceleration and acceleration curves
- Saving, loading and altering programs
- Error messages recognized by the system and saved for service

2.6 Safety Devices

Apart from the passive safety devices due to the instrument's mechanical design there are the following active precautions for your safety:

2.6.1 Lid Lock, Cover Closing Device

The centrifuge can only be started when the lid is correctly closed. Eight motorized steel bars and two motorized cover locks are locking and securing the lid. Both motorized locks must close. The lid can only be opened when the rotor has stopped. If the lid is open, the drive is completely separated from the mains supply, that means starting of the centrifuge is impossible (refer to point 8.5.4 "Emergency lid release").

2.6.2 Imbalance Monitoring System

In the event that uneven loading leads to imbalance, the drive is switched off during acceleration or during run.

2. Description of Centrifuge:

2.6.3 Excess Temperature in the Centrifuge Chamber

Once the temperature in the centrifuge chamber exceeds 50 °C, eg. due to a failure of the cooling device, the drive switches off. Restarting the centrifuge is only possible after cooling down.

2.6.4 Rotor Monitoring

During programming the rotor part no. and, if required, the bucket part no. must be entered. The computer checks, if the entered speed or the gravitational field is allowed for the rotor. Input errors are impossible (refer to point 8.3 "Entry limitations"). After starting, during the start-up phase, the computer additionally checks the identity of the rotor. **Attention: Please take care to enter the correct bucket part no. as the max. allowable speed could be exceeded by entering an incorrect bucket. This is not allowed.** If the rotor doesn't correspond to the programmed rotor no., STOP is carried out and an error message is issued. Restarting the centrifuge is only possible, when the rotor part no. has been corrected.

2.6.5 Standstill Monitoring

Opening of the centrifuge lid may only be possible, if the rotor is at standstill. This standstill is checked by the microprocessor and also by a second additional hardware circuit. Both monitoring devices must independently of each other have recognized that the rotor is at standstill before the lid can be opened.

2.6.6 System Check

An internal system check monitors data transmission and the sensor signals with regard to plausibility. The diverse malfunctions are recognized with utmost sensitivity, displayed as error message together with an error number and saved for service.

2.6.7 Earth Wire Check

For earth wire check there is a potential equalization screw at the rear panel of the centrifuge. An earth wire check can be carried out using an appropriate measuring instrument.

3. Installation, Start-up:

3.1 Unpacking of the Centrifuge

Open case. Take out box containing accessories. Remove the packing material. Take out centrifuge with the aid of a lifting device. When lifting or carrying the centrifuge please always reach under the instrument from the side.

Attention: The instrument is heavy!

Please keep case for possible transport of centrifuge later (refer to point 3.1.1 "Transport safety device/transport conditions").

3.1.1 Transport Safety Device/Transport Conditions

The SIGMA 8K 10 has no transport safety device.

Attention: Transport with installed rotor is not allowed! Always handle the rotor separate as otherwise damage to the motor suspension could occur.

3. Installation, Start-up:

3.2 Installation

3.2.1 Site

All energy consumed by the centrifuge is converted into heat and emitted into the ambient air. Therefore, sufficient ventilation is important. The air-ducts in the unit must be open. Also, the centrifuge shouldn't be positioned near radiators and direct insulation should be avoided.

A clearance of at least 30 cm around the centrifuge is necessary.

For normal operation the ambient temperature should not fall below 10 °C and not exceed 35 °C. The max. humidity of air is 80 %. During transport from cold to warmer places there will arise condensation water inside the centrifuge. It is important that there is enough time for drying before the centrifuge can be started again.

3.2.2 Connection

The operating voltage on the name plate must correspond to the local supply voltage!

SIGMA laboratory centrifuges are units of safety class I, DIN VDE 0700, and include a five wire power cord 2,5 m long with Cekon-plug.

3.2.3 Fuses / Emergency Circuit Breaker on Site

The centrifuges must be protected typically with at least 16 A slow acting fuses.

An emergency circuit breaker to cut the power to the centrifuge in the event of a malfunction is required on site. This switch should be located away from the centrifuge, preferably outside the room where the centrifuge is used or at the exit of this room.

3.2.4 Leveling on Site

After transport the castors should be relieved by screwing down the catches. Level centrifuge. Fix castors with locknut.

3. Installation, Start-up:

3.3 Insertion of Rotors and Accessories

1. Open centrifuge lid by pressing Lid-key K5.
2. Lower the rotor straight down onto the motor shaft.
3. Tighten the tie-down screw (clockwise) with the rotor spanner (SW 19) while holding the motor shaft with the hexagon socket spanner (SW 4). In the event of frequent use the tie-down screw must regularly be checked ensuring a proper connection between rotor and shaft (please refer to chapter 7.2 "Care and cleaning of accessories" as well).
4. Fill all positions of swing-out rotors with buckets. Take care of correct installation of buckets.
5. Use only appropriate vessels for the rotor (please refer to chapter 1.2 "Suitable accessories" as well).
6. Fill vessels external to the centrifuge.
7. Put or screw on covers of vessels.
8. Opposite places of the rotors must always be loaded with same accessories and same filling.
9. **Attention** when using microtiter rotors: It is important not to run the plate holders without plates inserted.
9. In angle rotors the plastic vessels must always be totally filled to avoid distortion of vessels and leakages or loosening of the caps in case of partial filling. **Attention**, follow the special comments of chapter 1.5.
10. **Attention**: The centrifuge will absorb smaller differences in weight when loading the rotors. But it is recommended to balance the vessels as accurately as possible in order to ensure a run with minimal vibrations. Should the centrifuge be operated with very uneven load, the imbalance device will switch off the drive and an error message appears on the display. The LED Imbalance (Ü1) of the monitoring panel is flashing (refer to 4.1 folding illustration at the end of the operating instructions).
11. Rotors with cover should always be run with their covers. The rotor cover is tightened with the rotor spanner. Never run windshield rotors without cover. Correct fastening must be ensured. Before installation of cover, the correct fastening of the rotor fixing screw must always be checked using a spanner.

3. Installation, Start-up:

12. Special instructions for the use of hermetically sealed rotors:

All rotors are autoclavable (refer to chapter 7.6 "Sterilization and disinfection of rotor chamber and accessories"). To increase life of rotors and seals the rotors must be greased with slushing oil and the seals and thread areas with vaseline or grease after cleaning.

3. Installation, Start-up:

3.4 Initial Start-Up

Attention!

Before initial start-up please take care that your centrifuge is orderly installed (refer to chapter 3.2 "Installation").

3.4.1 Switching on of the Centrifuge

Press mains switch (at the right of the control panel). When power is applied for the initial use, default values will be displayed:

- The displays (TD, PD, ZD, DD) are illuminated.
- The speed display (DD) indicates "2000".
- The time display (ZD) indicates "2.00".
- The temperature display (TD) indicates "20" without pre-cooling. With activated pre-cooling the actual chamber temperature appears.
- The program panel (PD) indicates "--",
(the above mentioned indications are default parameters, if program no. "--" is loaded), i.e.:
 - the centrifuge is to accelerate to 2000 rpm with curve no. 9,
 - the centrifuge operation is terminated after 2 minutes,
 - the cooling system is set to a temperature of 20 °C,
 - deceleration of the centrifuge is carried out with curve no. 9,
 - the values of the loaded program appear.

3.4.2 Opening Lid

Press Lid-key (K5).

- The lid opens.
- The display shows the set values.

3.4.3 Insertion of Rotor

Put a rotor onto the shaft and fasten it by screwing the rotor tie-down screw onto the shaft. Please use the supplied rotor spanner (refer to chapter 3.3 "Insertion of rotor and accessories").

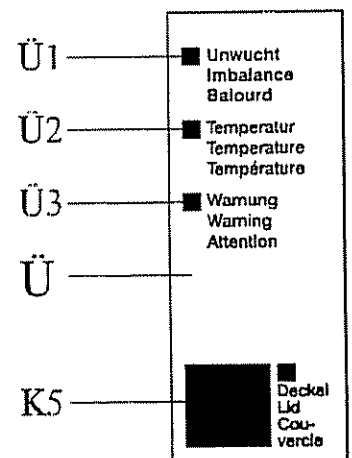

3. Installation, Start-up:

3.4.4 Selecting a Rotor or Bucket Number

Select LED "Rotor" (D3) by pressing the parameter key (DP) in the speed panel.

- LED "Rotor" (D3) is illuminated,
- a rotor part no. will appear on the speed display.

Pressing the Edit-key in the input panel activates the change mode (Edit-Aktiv-LED illuminated).

- Select the rotor number resp. bucket number by pressing the cursor keys until the correct number is displayed in the speed display,
- if a swing-out rotor with several available buckets had been selected, flashing rotor LED and display of "buc" in the time panel after pressing the Enter-key or parameter key request for input of bucket number,
- terminate input by pressing the Enter-key,
- with the new rotor number resp. bucket number new set values may be displayed.

3.4.5 Starting and Stopping a Run

Close the lid.

- The LED's of the Start-key (K1) and the Short-key (K2) are illuminated, indicating that operation can be started.

Conditions

- Entries must be completed.
- No active faststop.

Press the Start-key (K1) (for optional methods please refer to point 4.3.1 "Key Short (K2)"),

- the LED of the Start-key (K1) will extinguish,
- the LED's of the Stop and Faststop-keys (K3, K4) are illuminated,
- the motor accelerates to the set speed with the preselected curve, LED K5 will extinguish,
- the speed display (DD) indicates the current rotor speed.

Stopping a run in progress

Press the Stop-key (K3),

- the Start-key LED is illuminated again, indicating that the operation can be restarted by pressing the Start-key,

3. Installation, Start-up:

- the motor decelerates according to the set deceleration curve until it comes to a standstill,
- the display continues to indicate the current operational data.

Or:

Press the Faststop-key (K4),

- the Start-key LED will not light up,
- operation cannot be continued by pressing the Start-key,
- the motor decelerates with maximum deceleration to a standstill,
- the display continues to indicate the current operational data.

For starting please open and close the lid.

The run is over,

- the time display (ZD) changes to "0",
- the Start-key LED is illuminated, indicating that operation can be restarted by pressing the Start-key,
- the motor decelerates with the set deceleration curve up to standstill,
- the display continues indicating the current operational data.

Press the Lid-key (K5),

- the lid opens,
- the set values of the selected program are displayed again.

Note!

In the event of problems please refer to chapter 8.5 "Error correction".

4. Operating Elements:

4.1 Operating Panel (Folding Illustration at the End of the Operating Instructions)

All settings of the centrifuge are accessed via the operating panel. The switch activating the pre-cooling process is located at the left of the operating panel. The operating panel is divided into display panels and control panels.

4.2 Displays and Keys

- Speed panel (D)
- Time panel (Z)
- Program panel (P)
- Temperature panel (T)

The individual panels contain the following operator controls and displays:

Displays

(Displays are labelled by two letters, the latter one being a D: DD, ZD, PD, TD). The displays are located at the upper part of the panel. Because of a high intensity contrast, they are easy to read and allow for a simultaneous presentation of important data of the centrifuge operation (eg. speed, time, temperature, program no. etc.).

Light Emitting Diodes (LED)

(The LED`s are labelled by the letter of the corresponding panel and numbered in sequential order: eg. D1, D2, ...). The LED`s are arranged vertically below the displays. One of the LED`s is constantly on. It identifies the selection in the corresponding display.

Parameter Keys

(The keys are labelled with two letters, the latter being a P: TP, PP, ZP, DP). The parameter key is located at the bottom right corner of each panel. Pressing a parameter key of an active panel changes to the next parameter of this group. By pressing a parameter key of another panel the cursor changes to this panel. In the alteration mode the cursor is activated.

4. Operating Elements:

Input Keys

The input keys are divided in:

- Alteration keys
- Cursor keys
- Edit-key
- Enter-key
- Delete-key

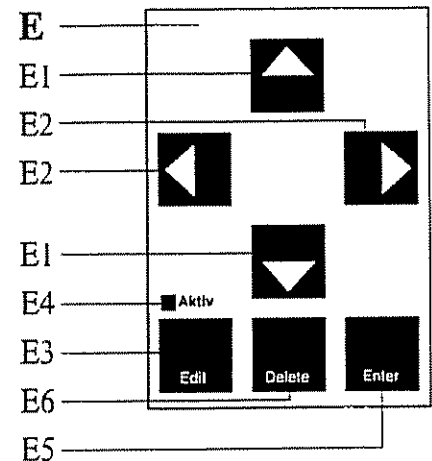

Alteration Keys

The alteration keys are labelled with ▲▼.

With these keys values can be increased ▲ or decreased ▼ by depressing the ▲ or the ▼ key.

Short pressing of the key results in one single counting step, holding the key in continuous steps with increasing speed. Counting terminates at the end of the respective value but can be continued by pressing the counting key again, resulting in an overflow.

Cursor Keys

The cursor keys are labelled with ◀▶.

The cursor position through the displays can be selected using the cursor keys. This is particularly advantageous, if extensive value alterations are necessary.

Edit-Key

The Edit-key is labelled with "Edit".

The Edit-key switches to the alteration mode (Edit-Aktiv-LED on).

The display changes from actual value display to set value display. After pressing the Edit-key again the alteration mode is terminated, possible changes of parameters are not saved.

Furthermore, saved programs can be loaded using the Edit-key.

4. Operating Elements:

Enter-Key

The Enter-key is labelled with "Enter".

With the Enter-key the parameter values are read and saved. They are also available after power off. The alteration mode finishes by pressing the Enter-key.

Delete-Key

The Delete-key is labelled with "Delete".

With the Delete-key programs, curves or intervals are deleted in the alteration mode by pressing the Delete-key and verified with the Enter-key.

4. Operating Elements:

4.3 Control Panels

4.3.1 Command Panel (K)

The centrifuge operation is started via the command panel. Keys can be pressed when their LED is on.

Start-key (K1)

This key can be used for the following:

- starting centrifuge operation,
- terminating a previously started deceleration process and restarting centrifuge,
- shifting to short-run at preselected speed. Pressing Start-key continuously for the time of the short run leads to acceleration max. to the set speed **with the reselected acceleration curve** and after release deceleration **with the preselected deceleration curve**. Max. range 9 min 59 sec.

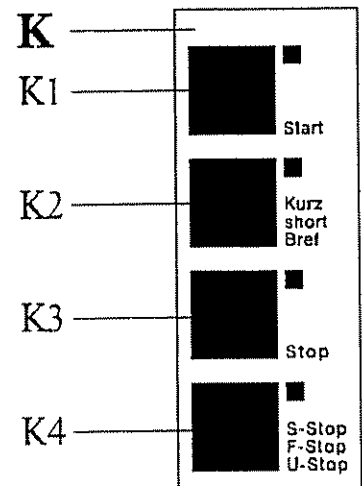

The centrifuge can be started when

- the lid is closed,
- no incorrect entries have been made,
- no LED's are flashing (except Rotor LED),
- the Start-LED is on,
- the Faststop-key has not been previously pressed,
- entries are finished.

Key Short (K2)

With this key the centrifuge can be accelerated to the max. speed of the rotor **with max. acceleration** and decelerated **with the max. deceleration curve** after releasing the key. Max. range 9 min. 59 sec.

Stop-key (K3)

This key can be used to terminate a run. The centrifuge decelerates according to the preset curve to a standstill. Deceleration can be terminated by pressing the Start-key again.

4. Operating Elements:

Faststop-key (K4)

Pressing this key decelerates the centrifuge as fast as possible. This deceleration process cannot be stopped, the centrifuge comes to a standstill in any case. Restarting is only possible after opening and closing the lid.

Lid-key (K5)

This key is used to open the lid. This can only be executed if

- the centrifuge has come to a standstill,
- the lid LED is on.

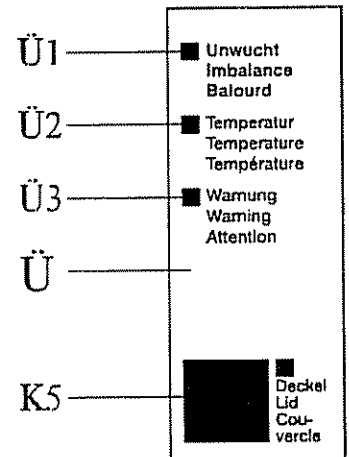

Command Panel (K)

The command panel (K) is located at the right side of the front panel. This corresponds to functions K1, K3, K4 and K5 in the operating panel.

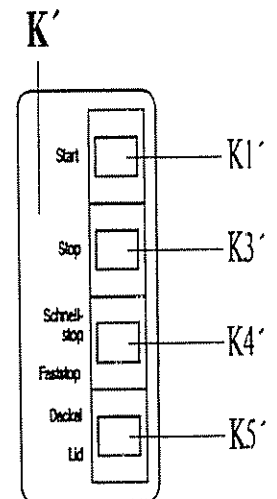

4. Operating Elements:

4.3.2 Key-Operated Switch (S)

With the key-operated switch the use of the centrifuge can be limited. The three switch positions are marked by LED's:

- Fix (S1)** - Starting, "Short" and "Open cover" during standstill only. The parameter keys remain active for calling the parameters.
- Universal (S2)** - Unrestricted operations.
- Stand-by (S3)** - The running centrifuge can be stopped only. The display extinguishes when the run is over. The "Stand-by" LED is illuminated. The refrigerating machine remains on with active pre-cooling.

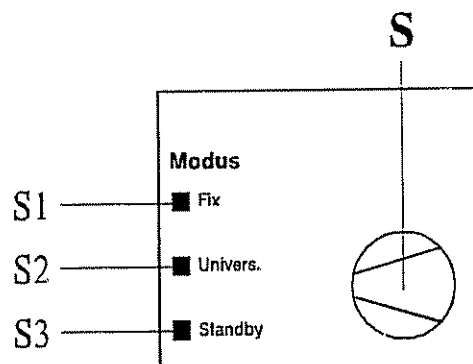

4. Operating Elements:

4.4 Display Panels

4.4.1 Speed Panel (D)

Speed (D1)

With entering a speed, the set value of the centrifuge speed is selected. After starting the centrifuge the current actual speed of the rotor is displayed.

RCF (D2)

The relative centrifugal force (abbrev. RCF) is an indication of the stress the sample is exposed to during a run. This value can be preset. The resulting speed is automatically calculated and displayed. After starting the run, the actual relative centrifugal force is displayed, if the RCF parameter is selected.

Rotors/Buckets (D3)

Rotor LED illuminated:

The desired rotors is selected via the alteration keys. All available rotors are offered for selection in the display in sequential order by pressing these keys. After selection of the desired rotor and display in the speed panel input is terminated by pressing the Enter-key. Pay attention to max. allowable speed.

After pressing the Enter-key or parameter key the Rotor LED is flashing, if various buckets are available for the set rotor. After selection of the desired bucket and display in the speed panel input is terminated by pressing the Enter-key.

Attention: Please take care that the correct bucket part number is entered as otherwise the max. allowable speed could be exceeded. This is not allowed.

Density (D4)

If the density of the liquid to be centrifuged exceeds 1.2 g/cm³, the corresponding value must be entered for safety reasons. The max. speed is decreased accordingly. Input range 1.2 to 9.9 (please refer to chapter 8.4.2 "Density").

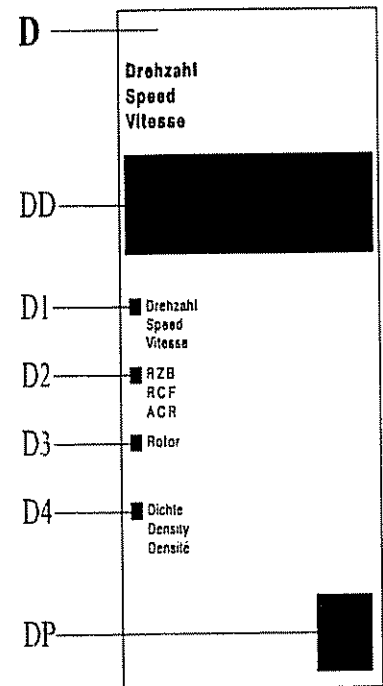

4. Operating Elements:

4.4.2 Time Panel (Z)

Time (Z1)

During standstill, this display shows the programmed time. During the operation of the centrifuge, the remaining run-time is displayed in

- minutes and seconds
- hours and minutes
- days and hours.

The time ranges can be selected via the alteration keys. The cursor must be set to the time range LED's. Time is defined as the period from starting the centrifuge to the beginning of deceleration, the maximum value is 9 d 23 h. Deceleration is activated after the programmed time is over.

Integral (Z2)

The integral is describing the dynamic stress the sample is exposed to. In order to display the high integral values, the exponential notation is used. It is covered by two displays: the speed display shows the four-digit mantissa, the time display the two-digit exponent. For further details please refer to chapter 5.6.3 "Specifying an integral".

Radius (Z3)

The radius is the horizontal distance between the middle of the rotor shaft and the inner bottom of the bucket.

Normally, the maximum value is automatically loaded. Entry of different radii in the range of R max and R min for calculation of the gravitational field is possible (please refer to chapter 1.2 "Suitable accessories").

The radii are displayed in cm. For further details please refer to chapter 5.6.1 "Specifying a relative centrifugal force (RCF)".

Start Delay (Z4)

The Start-delay can be set in minutes and seconds, hours and minutes or day and hours.

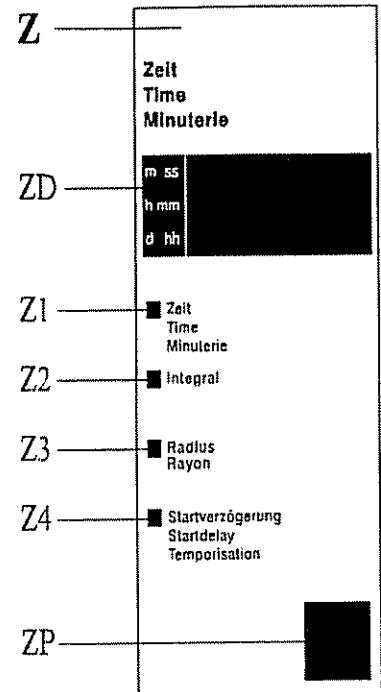

4. Operating Elements:

The entry 0 is deactivating the start-delay.

With a start-delay > 0 the time up to the start of the centrifuge will be displayed in the time panel by pressing the Start-key, the Start-delay LED is flashing. When the set time has elapsed, the centrifuge is started. Pressing the Stop-key deactivates the start-delay mode, the start-delay period is set to 0. The start-delay period is not saved with the programm data.

4. Operating Elements:

4.4.3 Temperature Panel (T)

Temperature (T1)

The centrifuge is temperature-controlled by a cooling system. When a run is started, there is a temperature difference between the sample and the rotor which is minimized after a certain operating period has passed.

During an operation, the temperature display indicates the actual temperature inside the rotor chamber. After pressing the Edit-key and the parameter key the set value is displayed in the temperature panel.

By entering a temperature, the desired temperature for the centrifuge chamber is set. Temperatures between -10 °C and +40 °C can be preselected.

As soon as the lid is opened, the cooling system is disconnected in order to avoid icing of the rotor chamber.

Precooling of the rotor below 0 °C during standstill is not recommended. Differences between actual and displayed temperature and icing of compressor would be the result. This would reduce life of the compressor. For lower rotor chamber temperatures we recommend precooling at 1000 rpm.

With an ambient temperature of +23 °C the obtainable lowest temperature is < +4 °C at maximum speed.

(A change of the limit values can cause deviations.) The obtainable temperatures depend on type of rotor, speed and ambient temperature.

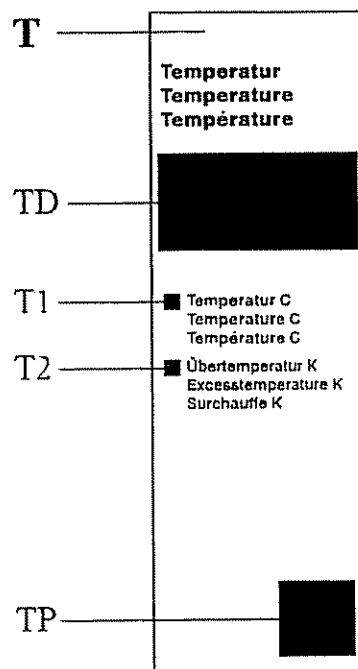

4. Operating Elements:

Excess Temperature (T2)

With the entry of an excess temperature a maximum chamber temperature relative to the set temperature is defined which should not be exceeded. The temperature range for the excess temperature is between 5 and 50 K above the set temperature. The centrifuge can be started outside these limits as well. Values eg.: Set value +4 °C, actual value +25 °C, set excess temperature 10 Kelvin. If the temperature does not decrease during operation, a malfunction of the refrigerating machine is recognized and the run is terminated. If the temperature decreases, the microprocessor assumes that the set temperature will be reached during run. The LED's in the monitoring panel are indicating the operating states (please refer to chapter 4.4.5 "Monitoring panel").

4. Operating Elements:

4.4.4 Program Panel (P)

Program (P1)

A program is loaded by entering a program code number. After power on, the last active program is loaded. Programs can be changed, saved again or deleted. For details please refer to chapter 5 "Programming".

Acceleration (P2)

The acceleration number selects an acceleration curve which the centrifuge follows until the final speed has been reached. Three different slopes are available:

0...9	linear slope
10...19	quadratic slope in the speed range up to 1000 rpm
20...29	freely programmable curves (if programmed)

Curves 0 to 19 are set by the manufacturer and cannot be changed by the user. Please refer to chapter 8.1 "Slope of the specified curves, linear curves" and 8.2 "Quadratic curves". Curves 0 to 9 are linear, curves 10 to 19 are quadratic in the speed range up to 1000 rpm. In the speed range exceeding 1000 rpm the acceleration is linear.

The acceleration is expressed by the curve slope. For example: curve no. 8 is steeper than curve no. 7, i.e. the centrifuge will reach the final speed within a shorter period.

Curves 9 and 19 apply the maximum acceleration to the centrifuge. These curves represent an exception. The centrifuge accelerates with maximum torque. The acceleration time only depends on the inertia of the rotor.

Acceleration curves 20 to 29 are user defined and can be applied over the entire speed range. They can only be selected if a curve had been entered with the corresponding number before. For further details please refer to point 5.7 "Programming variable acceleration and deceleration curves".

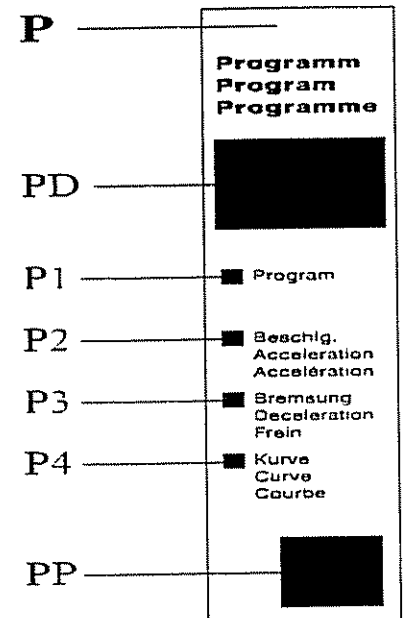

4. Operating Elements:

Deceleration (P3)

The deceleration number selects a deceleration curve which decelerates the centrifuge to standstill. The deceleration curves are inverted images of the acceleration curves and are labelled with identical numbers (except curve 0 = brakeless).

Curve (P4)

By selecting the Curve-LED the programming mode for freely programmable curves is activated (please refer to chapter 5.7 "Programming variable acceleration and deceleration curves").

4. Operating Elements:

4.4.5 Monitoring Panel (Ü)

In this panel possible warning limits during operation are indicated by three illuminated or flashing monitoring and warning LED's.

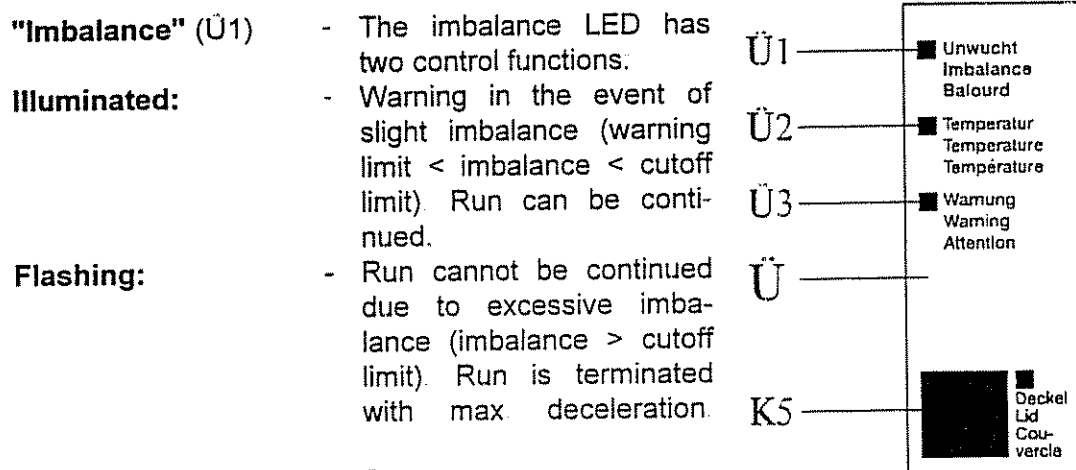

Reason:

Improper loading or malfunction during operation (eg. glass breakage) resulting in an uneven run.

"Temperature" (Ü2)

- Illuminated:**
- During run or precooling the temperature in the rotor chamber exceeds the entered excess temperature. The temperature LED is illuminated. If after 5 minutes the temperature will not decrease, the run is terminated and the LED is flashing.
- Flashing:**
- The entered cutoff limit cannot be reached within 5 minutes or is exceeded during operation. The run is terminated.

"Warning" (Ü3)

- This LED warns of the danger of glass breakage which might occur with the selected speed.

Note!

For further details please refer to chapter 8.5 "Error correction"

5. Programming:

What is considered a program?

A program contains all data that are required and can be selected for the operation of the centrifuge.

In other words, a program contains a sequence of key operations in a memory. This sequence of key operations can be loaded with one single operation to run the centrifuge with these values. A program is useful if a defined centrifuge operation should be repeated under same conditions.

A program saves time and helps to avoid entry errors which often could occur with repeated entries.

The program numbers are displayed in the program panel (PD). Max. 60 programs can be stored under numbers 0 - 59. Please use the forms of appendix 8.8 and 8.9.

The centrifuge is supplied with a standard program "--". With this program, an operation is possible at any time (please refer to chapter 3.4 "Initial start-up"). This standard program is overwritten with the entry of the first user program.

5. Programming:

5.1 Selection, Display and Alteration of Program Parameters

Set values

When in standstill, the centrifuge displays the last entered values (TD, PD, ZD, DD) in the temperature, program, time, and speed panel displays.

Actual Values

During the operation, the displays indicate the actual values.

The LEDs (T1, T2, P1-4, Z1-4, D1-4) below the displays indicate the parameters which the displays are currently showing. As a standard, the upper LED's are illuminated. The speed is displayed in the speed panel, the run time in the time panel, the temperature in the temperature panel and the program in the program panel.

The value of each of the parameters can be changed prior to a centrifuge operation by executing the following:

Press the Edit-key; the Edit-Aktiv-LED is illuminated. The third digit of the speed display is flashing.

You are in the alteration mode.

Press the parameter key (TP, PP, ZP, DP) of the display panel where the parameter should be changed (refer to chapter 4.1, paragraph "Cursor keys").

Select your parameter.

- This is executed by pressing the parameter key. The parameter values of the corresponding panel are displayed from top to bottom.
- The LED of the selected parameter illuminates.
- The digit of the display which should be changed is flashing, indicating that the user is still in the alteration mode.

Enter the new data via the alteration keys and save by pressing the Enter-key or recall existing data by renewed operation of the Edit-key.

- If a change has been made, the new value is stored. The programm number in the program panel is replaced by "--" showing that an unstored or altered program is used.

5. Programming:

5.2 Loading a Program (Calling up a Saved Program)

A program stored with a specific program number should be loaded, ie. it should be called up for starting the centrifuge:

- Activate the alteration mode by pressing the Edit-key.
- Activate the program panel (P) by pressing the program parameter key (PP). LED program is illuminated.

The available programs are displayed.

Select a program number using the alteration keys (program no. 0 - 59). A standard program "--" is always existent. The standard program "--" and stored programs can be called up using the alteration keys. Unused programs are displayed in the temperature panel "---", the time panel "----" and the speed panel "----". The individual parameters of each program can be called using the parameter keys. The program is loaded by pressing the Edit-key. The last active program or the parameter changed last is automatically loaded when the centrifuge is restarted.

If you want to change from program "--" to a stored program (eg. program no. 6), select the desired program number in the alteration mode and load program by pressing the Edit-key.

For further details please refer to chapter 5.1 "Selection, display and alteration of program parameters".

The centrifuge can be started using the selected program by pressing the Start-key (K1).

5.3 Changing and Saving a Program

Each change of a parameter, eg. time, temperature, acceleration curve etc. is a program change. In the program display (PD) "--" is displayed instead of the program number.

- Select alteration mode by pressing the Edit-key.
- Press the parameter key (DP, TP, ZP) of the panel where a parameter should be changed. The digit to be changed is flashing. The parameter could be changed.
- Activate the program panel (P) by pressing the program parameter key (PP).
- Select program number (0 - 59). Unused program numbers are displayed in the temperature panel "---", the time panel "---" and the speed panel "----".
- Press Enter-key.

Saving the program, if no program was existing under the selected number.

Display of "Pr", "quit" if a program is already existing under the selected number with the following options:

- Enter-key will overwrite the existing program
- Edit-key will terminate the storing process

Note!

Invalid entries or such exceeding the allowed limits are not accepted (please refer to chapter 8.3 "Entry limitations").

5.4 Deleting a Program

After activation of the alteration mode the program numbers to be deleted are selected using the alteration keys. The program "--" cannot be deleted. A program is deleted by pressing the Delete-key and by confirming "del" using the Enter-key.

5.5 Changing a Program During Centrifuge Operation

When the centrifuge is running, the following parameters can be changed:

- Speed
- RCF
- Run-time
- Time mode
- Deceleration curve while the centrifuge does not decelerate
- Acceleration curve while the centrifuge does not accelerate
- Temperature

Select the parameter to be changed using the parameter keys (TP, ZP, DP).

- The actual values are displayed.

Change the value using the Edit-key and the alteration keys (please refer to chapter 5.1 "Selection, display and alteration of program parameters").

- The actual values are displayed.

5.6 Programming the Relative Centrifugal Force, Density and Integral

A change of these parameters automatically results in recalculation and change of other parameters, because there is a direct mathematical relation between them (please refer to chapter 8.4 "Mathematical relation").

Entry limits cannot be exceeded when using the alteration keys.

5.6.1 Specifying a Relative Centrifugal Force (RCF)

The relative centrifugal force, abbr. RCF, is a measure for the rotational force on the sample. Its magnitude depends on the radius and the speed (refer to chapter 8.4.1 "Relative centrifugal force (RCF)").

During the operation, the RCF value (actual value) is continuously calculated and can be displayed by calling the parameter. Therefore, a control over the actual force can be obtained.

During standstill, the RCF value (set value) is calculated when a speed or a rotor number is entered. The RCF can be preset. The resulting final speed is then calculated and displayed.

Example:

- Switch to the speed panel, activate RCF and enter the new RCF data (eg. a lower value than the one calculated from the final speed).
- Change to the speed panel.
- The final speed has been recalculated.
- Change to the time panel and enter a smaller radius.
- The RCF value has been decreased.
- Increase the final speed controlling the RCF at the same time until the originally set RCF value is obtained again.

Result:

By decreasing the radius, a higher final speed is required in order to obtain an identical RCF value.

5.6.2 Specifying a Density

If the density of a liquid to be centrifuged exceeds 1.2 g/cm³, the max. speed for the rotor reduces.

The centrifuge is able to calculate the reduced max. speed, if the parameter "Density" in the speed panel is activated (LED D4 illuminated) and the higher density is entered via the alteration keys (E1). The entry range of the density value is between 1.0 and 9.9.

A value exceeding 1.2 g/cm³ decreases the maximum possible final speed (please refer to chapter 8.4.2 "Density").

Note!

When working with sedimentation constants, the required time constant can be calculated with the aid of the integral, if the initial speed had been reduced due to excessive density (please refer to chapter 5.6.3 "Specifying an integral"). Calculation proceeds as follows:

- Enter initial program data.
- Read corresponding integral value.
- Enter actual density (the initial speed and the initial integral value are reduced).
- Enter initial integral value (the corresponding run-time is calculated).

The run can be started with the initial sedimentation constants.

5.6.3 Specifying an Integral

The integral is a measure of the dynamic load the sample is exposed to. This value is displayed in exponential form. The four-digit mantissa is displayed with a preceding "n" in the speed display and the two-digit exponent with a preceding "E" in the time display.

During operation, the integral is constantly determined. Its value depends on the speed and the elapsed centrifuge run-time. The value increases constantly (please refer to chapter 8.4.3 "Integral").

The actual values of the integral can be displayed during a run or thereafter.

It is possible to set an integral.

The following factors are considered when calculating an integral:

- Run-time
- Final speed
- Acceleration curve
- Deceleration curve

If a new final speed is entered directly before the entry of a set integral, the centrifuge automatically determines the total run-time. In all other cases the final speed is determined.

Automatic conversion of the run-time is also useful, if the max. speed must be reduced by reason of high specific density of the material and thus the run-time must be increased (refer to chapter 5.6.2 "Specifying a density").

Example:

- Specify new final speed data, run-time values and acceleration curves in sequential order.

The resulting integral changes.

- Specify a smaller integral.

The resulting final speed decreases.

- Specify an integral after having altered the final speed.

The resulting run-time changes.

5. Programming:

5.7 Programming Variable Acceleration and Deceleration Curves

Apart from 20 fix acceleration and deceleration curves, curves are freely programmable as well. Up to 10 different curves can be stored under no. 20 - 29 (please refer to chapter 4.4.4 "Program panel - acceleration").

Up to 10 intervals can be specified in an acceleration or deceleration curve. An interval is defined by its run-time and the speed to be obtained at the end of the interval. The final speed of the last interval should correspond to the operating speed for the centrifuge run. If the final speed of the last interval does not correspond to the operating speed the centrifuge calculates the acceleration time from the set curve slope (change of speed/time interval). For the first interval, a quadratic resp. linear acceleration can be preselected via the alteration keys. "q" in the temperature panel indicates quadratic acceleration, "L" linear acceleration. The following intervals are always linear.

Only acceleration curves are programmed. The deceleration curves are inverted images. Each acceleration curve is also applicable as a deceleration curve.

Activate the curve mode for programming:

- Activate the alteration mode by pressing the Edit-key.
- Select LED curve in the program panel using the parameter key (PP), LED curve is illuminated.
- Press the alteration keys (E1). The curve mode is active. This mode can only be left by pressing "Enter" (curve is saved) resp. "Edit" (changes are refused).
- The last active curve no. is displayed in the program panel resp. curve 20 during initial programming. When pressing the alteration keys (E1) the display changes to the next available curve number. A desired curve number can be entered via the alteration keys.

The last digit of the temperature display shows the step number "0", the digit in front of it "q" for quadratic or "L" for linear curve of the first step. Pressing the alteration keys changes from "q" to "L" after the parameter key in the temperature panel (TP) had been pressed.

The speed display (DD) shows the obtainable speed per interval.

The time display (ZD) shows the run-time of the interval in minutes/seconds, hours/minutes or days/hours after which the centrifuge should reach the set interval speed.

5. Programming:

The temperature display: "q" for quadratic acceleration
"L" for linear acceleration
(0 - 9) number of intervals

With a new curve the speed and time displays are showing "0".

With the cursor keys (E2) any display position can be selected, if the corresponding value can be changed. The flashing value can be changed via the alteration keys (E1). The time ranges in the time panel can be changed via the alteration keys. In the event of too short intervals the max. interval speeds are adapted.

Setting speed and time for an interval:

The interval number is selected in the temperature panel via the alteration keys. If an interval contains no data, higher interval numbers cannot be selected.

The values for an interval can be set in the time and speed panel. The max. possible speed depends on the time selection and the speed values of the adjacent intervals. The acceleration calculated from the set speed and time values of the adjacent intervals must not exceed the maximum acceleration. Due to this check it is not possible to exceed the maximum speed resp. the shortest time value.

Comment

The max. speed of the curve is below the set operating speed: After reaching the end of the curve the centrifuge will accelerate to the set speed value and vice versa with the acceleration value the curve followed at the end.

5.7.1 Deleting Intervals

If the number of intervals of a curve should be reduced, the corresponding interval no. is selected using the alteration keys. This and all following intervals are deleted via the Delete-key (E6).

5.7.2 Changing a Programmed Curve

Select the position to be changed in the curve mode using the cursor key (E2). The corresponding digit is flashing.

The value can be entered via the alteration keys (E1). If all curve numbers are allocated, new entries can be made by overwriting or changing existing parameters (please refer to chapter 5.3 "Changing and saving a program").

5. Programming:

5.7.3 Example: Specifying a Program with a Freely Programmable Curve

An acceleration curve is programmed under a number between 20 and 29. Its absolute final speed should be 3100 rpm. The speed should be obtained in three interval steps. The total interval period is 4 minutes, the total run-time 6 minutes, temperature 20 °C.

Interval	Type	Time (min)	Speed (rpm)	Comment
0	q	1	1000	quadratic acceleration within 1 min. to 1000 rpm
1	L	2	2000	linear acceleration within 2 min. to 2000 rpm
2	L	1	3100	linear acceleration within 1 min. to 3100 rpm

(see speed-time-slope, picture 1)

Condition: Input of final speed, time and temperature.

Proceeding (only during standstill):

- Press Edit-key: Edit-mode active.
- Press programm parameter key (PP) until curve LED is reached: -
- Press alteration key (E1): Curve mode active.
- Press temperature parameter key (TP): Interval no. is flashing (0).
- Press left cursor key (E2): L (linear) is flashing.
- Press alteration key (E1): Select "q" für quadratic acceleration in interval no. 0.
- Press time parameter key (ZP): Time panel is flashing, set 1 minute via E1/E2.
- Press speed parameter key (DP): Speed panel is flashing, set 1000 rpm via E1/E2.
- Press temperature parameter key (TP): Interval no. 0 is flashing.
- Press upper alteration key (E1): Interval no. 1 is flashing.

- Input of "1." and "2." interval as interval "0".

- Save via "Enter": Freely programmable curve 20 has been entered and will be available when required.

- After selection of the desired acceleration curve the run can be started by pressing the Start-key (K1).

5. Programming:

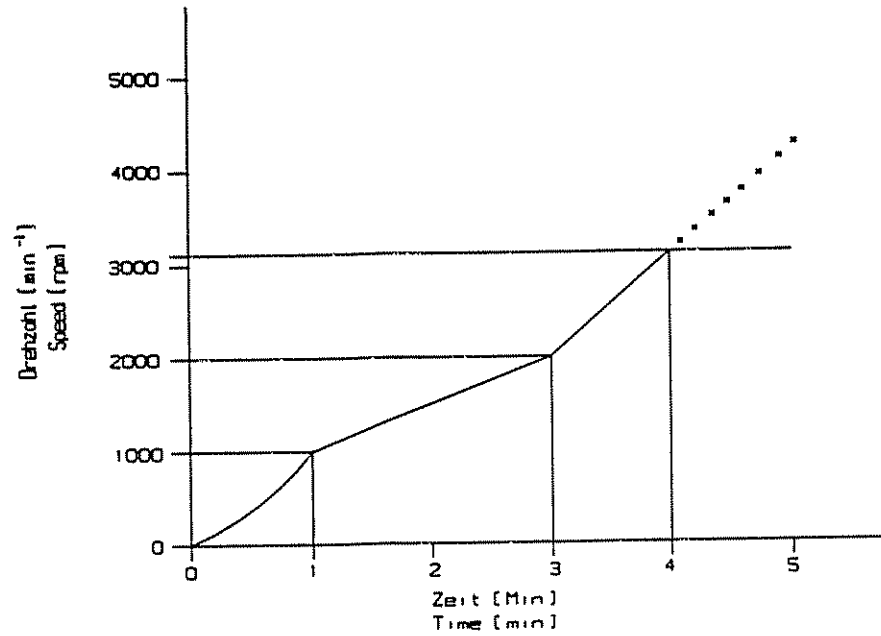

Picture 1, Speed-Time-Slope

5. Programming:

5.8 Pre-Cooling

The centrifuge can be pre-cooled after power on by pressing switch "Standstill refrigeration". The temperature is regulated to the set value.

Conditions: - Power on
- Lid closed

6. Notes for Centrifugation:

6.1.1 Practical Notes for Centrifugation

1. Locate centrifuge horizontally on a level surface.
2. Ensure safe location.
3. Keep at least 30 cm free space around the centrifuge.
4. Provide for sufficient ventilation.
5. Tighten rotor firmly onto motor shaft.
6. Avoid imbalance.

7. Load opposite buckets with same accessories.
8. Centrifugation with different tubes: Working with different tube sizes is possible. Opposite places must be loaded with the same vessels (see illustration).

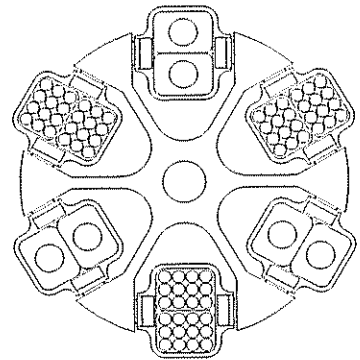

Centrifugation with low capacity:

The vessels should be placed symmetrically so that the buckets and their suspensions are loaded evenly. Loading an inner or outer position of the bucket only is not allowed (see illustration). Even angle rotors should be loaded symmetrically to same weight.

9. Load all positions of swing-out rotors.
10. Load vessels outside the centrifuge.
11. Please pay attention to the max. speed of glass tubes. At speeds over 4 000 rpm there is an increased breaking glass hazard (see warning LED (Ü3)).
12. Fill vessels carefully to same weight. Imbalances would result in increased wear of bearings.
13. Grease joints of buckets and rotor pins of swing-out rotors.
14. Use perfect accessories only.

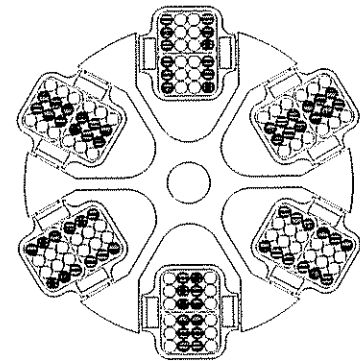

6. Notes for Centrifugation:

15. Avoid corrosion to accessories by careful maintenance.
16. Spin infectious material in sealed rotors and buckets only.
17. Do not spin explosive or highly inflammable materials.
18. Record all program data, refer to forms of appendix chapter 8.8 and 8.9.
19. When centrifuging substances with a density $> 1,2 \text{ g/cm}^3$ the allowable max. speed must be reduced (refer to chapter 8.4.2 "Density").

6. Notes for Centrifugation:

6.1.2 Important Notes for the Centrifugation of Blood Bag Systems

The centrifuge SIGMA 8K10 accepts high imbalances (approx. 50 g).

For a best possible sedimentation it is important to balance the buckets weight carefully.

All 6 places of the rotor have to be loaded with buckets. It is however permissible to fill just two opposite buckets with a total of 4 blood bag systems.

The weight of the opposite buckets incl. filled blood bag systems has to be equal.

The blood bags have to be put into the opposite buckets mirror-inverted.

In both bucket chambers the main blood bag should be inserted towards the centre of the bucket. The opposite bucket has to be loaded accordingly.

When using smaller bag systems or in case of incompletely filled blood bags adapters e.g. part no. 17750 have to be inserted together with the blood bag systems. This will avoid slipping of the bags which could result in an imbalance.

For the centrifugation of human blood suitable acceleration and especially deceleration curves have to be used.

Curve no. 12 is most suitable, or customers could create their own curves (refer to point 5.7 "Programming variable acceleration and deceleration curves").

6. Notes for Centrifugation:

Centrifugation of human blood

A German blood bank is working successfully using the following data:

Temp. °C	Speed rpm	RCF x g	Time min.	Acceler. curve no.	Deceler. curve no.	Programme
22	3750	4544	7	20 2 min.	12	1 Full blood
22	3570	4544	10	20 2 min.	12	2 Full blood in 4fold bags
20	4000	5170	12	24 3 min.	12	3 Plasma with buffy coat
22	3750	4544	9	20 2 min.	12	4 Full blood
20	4000	5170	14	24 3 min.	12	5 Plasma with buffy coat
22	1094	384	7	21 2 min.	11 or 2 min.	6 Platelets with buffy coat
22	1094	384	7	21 2 min:	1 or 3,5 min.	7 Platelets with buffy coat

In case that the used centrifuge would not reach the mentioned RCF values, the user should set the maximum gravitational field and run the centrifuge for a longer period.

Curves no. 20, 21 and 24 are freely programmable time/speed curves.

The programs no. 1 to 5 can be run in SIGMA 6K15 as well. Please set RCF, time, temperature, acceleration curve 12 and deceleration curve (12 only).

6. Notes for Centrifugation:

6.2 Forbidden Centrifuging Operations

1. Exceeding the max. allowable speed of the used rotors resp. buckets. Please pay attention to the max. allowable speed in any case (bucket engraving).
2. Operation of not carefully installed centrifuge.
3. Operation without front or back panels.
4. Operation by non authorized personnel.
5. Operation with rotor not installed properly (refer to chapter 3.3)
6. Operation with incompletely loaded drum rotor, swing-out rotor or angle rotor with interchangeable buckets.

A rotor must always be loaded completely, empty places are not allowed!
Opposite buckets or carriers may nevertheless be empty. Mixed loading is allowed, if opposite places are loaded with same buckets and carriers of same weight.

7. Operation with overloaded rotors.

The load for a rotor is limited by its design and the max. speed (see rotor/bucket engraving) and must not be exceeded. The rotors are intended for liquids of max. homogeneous density of 1.2 g/cm³ if centrifuged at max. speed. If liquids of higher density are used, the speed must be reduced accordingly (refer to chapter 8.4 "Mathematical relation").

8. Operation with rotors, buckets and carriers showing corrosion or other defects.
9. Operation of very corrosive substances which can cause damages to material and effect mechanical strength of rotors, buckets and carriers.
10. Operation of rotors and accessories not allowed by the manufacturer, except commercial vessels of glass or synthetic materials. The use of poor commodity goods is not recommended. At high speeds breaking glass or bursting vessels can cause dangerous imbalances.
11. With plastic bottles 250, 500 and 1000 ml the max. speed of 7 000 rpm must not be exceeded due to increased risk of breakages.
12. Operation in hazardous locations.
13. Operation with vessels of improper size.
14. Centrifugation of improper material.

6. Notes for Centrifugation:

15. Operation with partially filled plastic tubes in high-speed angle rotors.
16. Lifting or moving of the centrifuge during operation. Leaning against or resting on the centrifuge is not allowed.
17. Do not place potential dangerous material - eg. glass vessels containing liquids - near the centrifuge
18. Attention. Do not open cover and/or reach into rotor chamber unless the rotor is at standstill. Never attempt to override the lid interlock system while the rotor is spinning.
19. The condensate drain must be closed during centrifugation (refer to chapter 7.1).
20. Do not spin substances which could react upon the supply of high energy during centrifugation.
21. Do not spin explosive or highly inflammable materials.
22. Substances which could damage the material of the centrifuge, the rotors or the buckets anyhow must not be centrifuged or only under consideration of special safety measures. Infectious, toxic, pathogene or radioactive substances must be centrifuged in certified rotors and vessels only.

7. Care and Maintenance:

7.1 Care and Cleaning of Centrifuge

Please use soap water or other water-soluble, mild agents for cleaning. Avoid corroding and aggressive substances. Do not use alkaline solutions or solvents or agents with abrasive particles. Before using detergents or decontamination agents which had not been recommended by us, the user has to contact us to make sure that such procedure would not damage the centrifuge.

Remove product particles from the rotor chamber using a cloth or paper towel. It is recommended to open the cover when the centrifuge is not in use so that moisture can evaporate. Increased wear of the motor bearings will thus be avoided. **If there is the risk of toxic, radioactive or pathogene contamination, special safety measures must be kept.**

Condensate drain

When required, but at least once a week, the condensate in the centrifuge chamber must be drained via the discharge. Attention! Only during standstill of the centrifuge! The discharge is located in the front panel below the ventilation grid and carries a sign. The condensate drains via a boring in the bottom plate below the discharge. Please use the supplied drip cup.

Attention!

Close the discharge before restarting the centrifuge (slot of screw in horizontal position).

7.2 Care and Cleaning of Accessories

For care of accessories special safety measures must be considered as these are measures ensuring operational safety at the same time.

Buckets, trunnions and also synthetic buckets are produced exactly in order to withstand the permanent high stress with high gravitational fields.

Chemical reactions as well as stress-corrosion (combination of changing pressure and chemical reaction) can effect or destroy the metals. Hardly detectable cracks on the surface expand and weaken the material without visible signs. When detecting a visible damage of the surface, a crack, a mark or any other change, also corrosion, the part (rotor, bucket etc.) must be replaced immediately.

In order to avoid corrosion, rotor incl. tie-down screw and cover seal, buckets and carriers must be cleaned and greased regularly with the supplied slushing oil (part no.: 70104 for 20 ml slushing oil). Before using detergents or decontamination agents which had not been recommended by us, the user has to contact us to make sure that such procedure would not damage the centrifuge. The rotor tie-down screw must be greased using the supplied grease (part no.: 70284).

7. Care and Maintenance:

Cleaning of accessories should be carried out external to the centrifuge once a week or preferably after every use. The rubber cushions should be removed from buckets and carriers. After this the parts should be dried with a soft cloth or also in a drying chamber at approx. 50 °C. **If there is the risk of toxic, radioactive or pathogene contamination, special safety measures must be kept.**

Especially aluminium parts are extremely corrosive. A neutral cleaning agent with a pH-value between 6 and 8 should be used for such parts. Alkaline agents exceeding pH 8 must be avoided. Especially aluminium parts must be greased regularly with slushing oil. This procedure essentially increases life time and reduces corrosion.

Careful maintenance increases life time and avoids premature failure of the rotor. Corrosion or resultant damages which are caused by insufficient care do not constitute a warranty claim.

7.3 Rotor Pins

The trunnion pins of the rotor should always be greased as only this ensures evenly swinging of buckets and thus quiet run of the centrifuge (part no. 70284 Grease).

7.4 Glass Breakage

In case of glass breakage all glass particles must be carefully removed. Rubber inserts have to be cleaned carefully and possibly be replaced. If a problem has occurred, the following has to be considered:

Glass particles in the rubber cushion will cause glass breakage again.

Particles on the rotor pins prevent buckets and carriers from swinging evenly which will cause an imbalance.

Glass particles in the centrifuge chamber will cause metal abrasion due to the strong air circulation. This dust will not only pollute the centrifuge chamber, the rotor, the buckets, the carriers and the material to be centrifuged but also damage the surfaces of the accessories, the rotors and the centrifuge chamber.

In order to totally remove the glass particles and the metal dust from the rotor chamber, it is advisable to grease the upper part of the centrifuge chamber with eg. Vaseline. Then the rotor should rotate for some minutes at a moderate speed. The glass and metal particles will now collect at the greased part and can easily be removed with a cloth together with the grease. If necessary repeat this procedure.

7. Care and Maintenance:

7.5 Care and Cleaning of the Condenser

A lamellar condenser is used to cool the compressed refrigerant. It is installed at the back of the centrifuge and cooled with air.

The location for the centrifuge should therefore be as clean as possible, ie. dirt, dust etc. should not prevent the air from streaming through the condenser and obstruct heat transfer. Dust on the condenser pipes and the lamella will reduce heat exchange and decrease the performance of the refrigerator.

The condenser should therefore be regularly checked for dirt and cleaned if necessary. Generally blowing of the lamella with compressed air from inside and outside is sufficient (or a simple hoovering with a vacuum cleaner).

7.6 Sterilization and Disinfection of Rotor Chamber and Accessories

All usual disinfectants like eg. Sagrotan, Buraton or Terralin (to obtain at chemist's shops) can be used. The centrifuges and the accessories consist of different materials. A possible incompatibility must be considered. Before using detergents or decontamination agents which had not been recommended by us, the user has to contact us to make sure that such procedure would not damage the centrifuge. For sterilization by steam resistance to temperature of the individual material must be checked (refer to point 7.6.1 "Autoclaving"). Please contact your laboratory safety officer regarding proper methods to use. **If dangerous materials are used, the centrifuge and the accessories must be disinfected.**

Principally we want to point out that for centrifuging of eg. infectious material certified and hermetically sealed accessories have to be used in order to avoid that the centrifuge is contaminated.

7. Care and Maintenance:

7.6.1 Autoclaving

The life of the accessories essentially depends on the frequency of autoclaving and use. When the parts are showing changes in colour or structure or in the event of leaks etc., the accessories have to be replaced.

During autoclaving the caps of the tubes must not be screwed on to avoid deformation of the tubes. It can not be excluded that plastic parts, e.g. lids or carriers, would deform during autoclaving.

Autoclaving:

Accessories	max. temp. °C	min. time min	max. time min	max. cycles
Glass tubes	134-138	3	5	-
Polycarbonate tubes	115-118	30	40	20
Polypropylene tubes	115-118	30	40	30
Teflon tubes	134-138	3	5	100
Aluminium rotors	134-138	3	5	-
Polypropylene rotor 12034	115-118	30	40	20
Polypropylene rotor 12124	115-118	30	40	20
Polycarbonate/Polyallomer lids for angle rotors	115-118	30	40	20
Polysulfone lids for angle rotors	134-138	3	5	100
Aluminium buckets	134-138	3	5	-
Polycarbonate caps for buckets	115-118	30	40	50
Polypropylene caps for buckets	115-118	30	40	50
Polysulfone caps for buckets	134-138	3	5	100
Rubber adapters	115-118	30	40	-
Rubber cushions	115-118	30	40	-
Round carriers for 13104/ 13117, Polypropylene	115-118	30	40	-
ditto, Polyallomer and Polycarbonate	115-118	30	40	-
Round carriers for 13350/ 13550, Polypropylene	115-118	30	40	-
Rectangular carriers, Polypropylene	115-118	30	40	-
ditto, Polyallomer and Polycarbonate	115-118	30	40	-

7. Care and Maintenance:

7.7 Checks by Operator

The operator has to pay attention that important parts of the centrifuge necessary for safety are not damaged.

This especially refers to:

1. Motor suspension
2. Concentricity of the motor shaft
3. Fastening of the trunnions in the rotor
4. Rotors and accessories have a limited life. For safety reasons a regular check is recommended after 50.000 cycles. Any changes like e.g. corrosion, cracks, material abrasion etc. require special attention.
5. Screw connections have to be tight.

Furthermore, the earth wire must be checked regularly.

8. Appendix:

8.1 Slope of Specified Curves, Linear Curves

- The slope of a specified acceleration curve is defined as the time required to accelerate the rotor to 1000 rpm.
- With linear and quadratic slopes, curves are numbered in the direction of increasing acceleration (from right to left).
- The deceleration curves are inverted images of the acceleration curves with the same numbers (exception: curve 0).
- Curve 0 decelerates brakeless.

Comment: The acceleration time depends on the moment of inertia of the rotor.

Linear Curves (0 - 9)

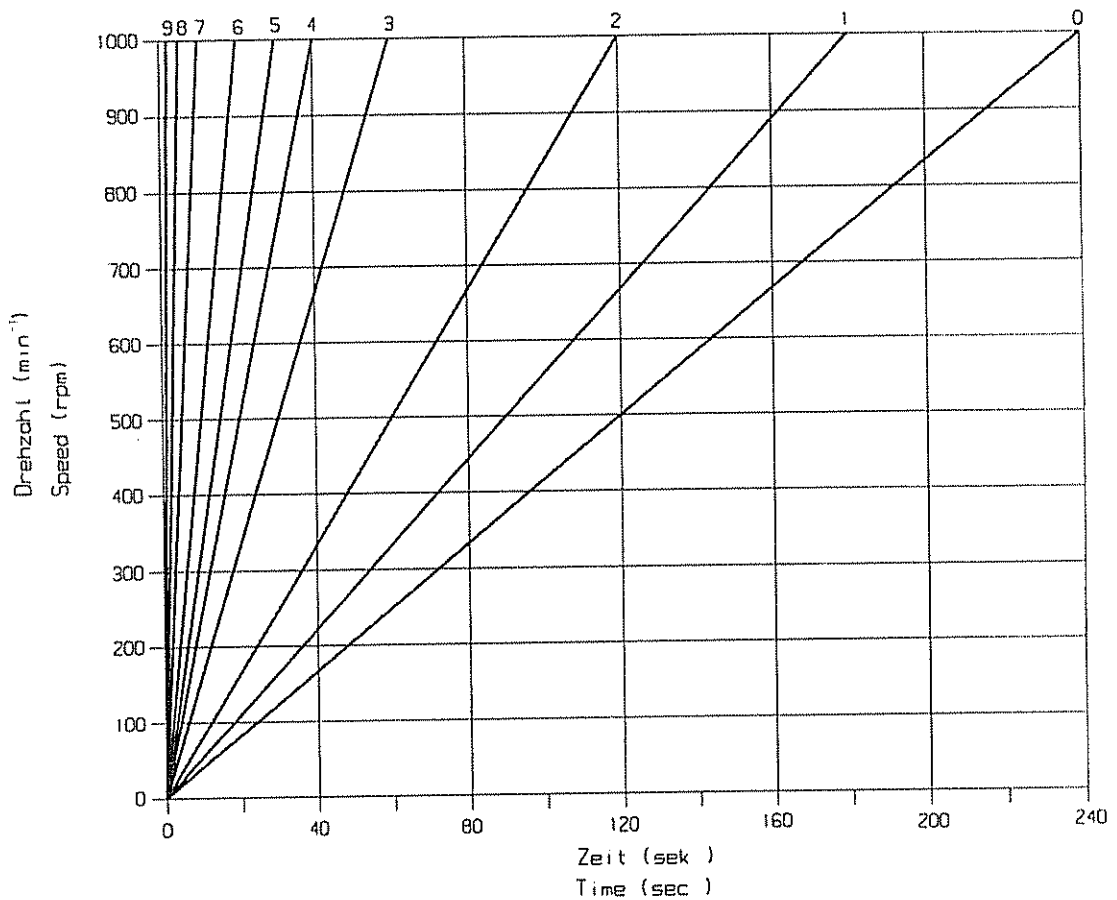

Figure 2

8. Appendix:

The curve 9 is a special case compared with the other curves. The centrifuge accelerates with max. torque. The acceleration time only depends on the moment of inertia of the rotor.

Linear curve no.	Slope
0	240 sec./1000 rpm.
1	180 sec./1000 rpm.
2	120 sec./1000 rpm.
3	60 sec./1000 rpm.
4	40 sec./1000 rpm.
5	30 sec./1000 rpm.
6	20 sec./1000 rpm.
7	10 sec./1000 rpm.
8	5 sec./1000 rpm.
9	0,9 sec./1000 rpm.

8.2 Quadratic Curves

- The deceleration curves are inverted images of the acceleration curves with the same numbers.

Quadratic Curves (10 - 19)

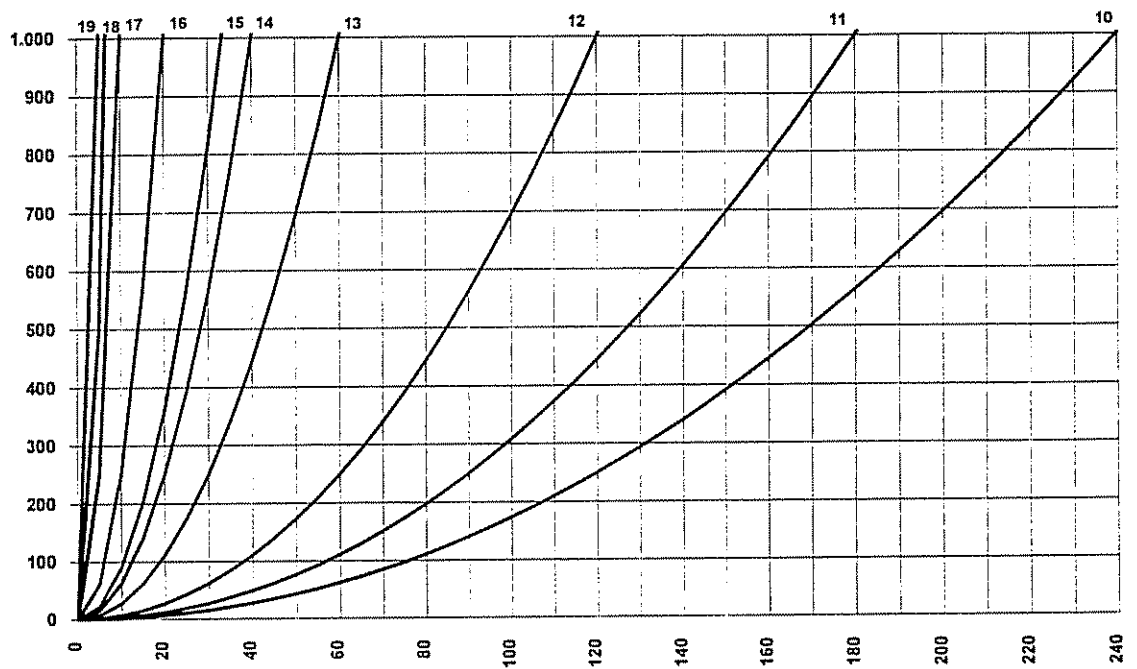

Figure 3

The curve 19 is a special case compared with the other curves. The centrifuge accelerates with maximum torque. The acceleration time only depends on the moment of inertia of the rotor.

8. Appendix:

Quadratic curve no.	Time up to 1000 rpm	Slope from 1000 rpm linear
10	240	120 sec./1000 rpm.
11	180	90 sec./1000 rpm.
12	120	60 sec./1000 rpm.
13	60	30 sec./1000 rpm.
14	40	20 sec./1000 rpm.
15	30	15 sec./1000 rpm.
16	20	10 sec./1000 rpm.
17	10	5 sec./1000 rpm.
18	5	2,5 sec./1000 rpm.
19	0,9	0,5 sec./1000 rpm.

8.3 Entry Limitations

The entry of speeds exceeding the maximum allowable speed of the rotors resp. buckets is not allowed. Please pay attention to the maximum allowable speed for each rotor-bucket combination (bucket engraving).

8.4 Mathematical Relation

8.4.1 Relative Centrifugal Force (RCF)

The parameters speed, RCF and the diameter of the rotor are interrelated via the following formula:

$$\text{RCF} = 11,18 \times 10^{-6} \times r \times n^2$$

If two values are given, the third value is determined by the equation. If the speed or the rotation radius are changed, the resulting RCF will be recalculated. If the RCF is altered, the speed under consideration of the radius is adapted accordingly.

8.4.2 Density

If the density of the liquid is higher than 1.2 g/cm³, the allowed maximum speed of the centrifuge is calculated according to the following formula:

$$n = n_{\text{max}} \times \sqrt{(1,2 / \text{Rho})}$$

Rho = density in g/cm³

8.4.3 Integral

The integral is describing the dynamic and speed-dependent stress to the sample during centrifuge operation.

During a run the actual integral is constantly calculated and displayed.

To assist the user when entering new speed-time curves, the set integral is determined. With freely programmable curves, the speed-time course is defined per interval.

$$I = \int_0^r Q^2 dt = \int_0^r (\pi / 30)^2 * n^2 dt = (\pi / 30)^2 \int_0^r n^2 dt$$

Due to small deviations between the set and actual speed during the acceleration phase differences between the set and actual value of the integral might occur. With extremely long run-times, especially with small speed values, the calculation of the actual integral could be incorrect.

Dimensions:

- n in rpm
- r in cm
- RCF without dimension
- I in 1/s
- Gamma in g/cm³

8.5 Error Correction

Most of the errors can be reset by power off/on. In the event of a short power supply failure during a run, this run is interrupted and can be continued by pressing the Start-key.

No indication on the display: Actions:

- | | |
|---|--|
| – No voltage in the socket? | • Check fuse in mains supply. |
| – Power cord plugged in and line voltage present? | • Plug in power cord correctly. |
| – Input fuse ok? | • Replace input fuse (see nameplate for rating). |
| – Power switch on? | • Switch on power. |
| – Key operated switch in position „Stand by“? | • Turn key switch to “Universal”. |

8.5.1 Centrifuge cannot be Started

a) Start-key LED not illuminated:

- | | |
|-------------------------------|---|
| – Edit-Aktiv-LED illuminated. | • Edit-Active-Mode is left by pressing the Enter-key or the Edit-key. |
| – Lid-LED not illuminated. | • Close lid. Lid locks must close. |

b) Start-key LED illuminated:

- Power off/on. If error occurs again, call service.
- Pay attention to start delay.

8.5.2 Centrifuge Decelerates during Operation

a) Imbalance-LED (Ü1) flashing:

- | | |
|--|--|
| – Rotor is loaded unevenly. | • Balance loading. |
| – Centrifuge tilted. | • Align centrifuge. |
| – Drive error (mechanical damage). | • Call Service. |
| – Centrifuge was moved during operation. | • Restart after opening and closing lid. |

b) Temperature LED (Ü2):
LED flashing:

- Excessive chamber temperature.
- Excess temperature has been exceeded.
- Sensor connection cable defective.
- Let cool down.
- Check preselection.
- Call Service.

c) Start-key LED not illuminated:
Lid-LED not illuminated:

- Cover cannot be closed properly.
- Power off, open lid via emergency lid release (refer to chapter 8.5.4).

d) Start-key LED not illuminated:
Lid-LED illuminated:

- Edit -mode active.
- Edit mode is left by pressing the Enter-key.

e) Start-key LED illuminated:
Lid-LED illuminated:

- Start-delay active.
- Power off/on, if error occurs again, call service.
- Pay attention to start-delay.

f) General error:

- Installed rotor is different from entered rotor number.
- After power on an error number 69 to 77 is displayed.
- Correction of rotor number.
- These error numbers indicate an error in the internal permanent memory. Error could eg. occur in the event of a power supply failure during saving.

8.5.3 Lid cannot be Opened/Closed

- a) Slightly lift the lid when opening.
- b) Only one lid lock unlocked, call service.

8.5.4 Emergency Lid Release

In the event of a power supply failure it is possible to manually open the lid, please proceed as follows:

1. Wait until rotor is at standstill (power off).
2. Remove stopper in the middle of the lid with a screw driver.
3. Put supplied square wrench onto visible square shaft and turn in clockwise direction.
4. Remove left and right stopper in the front panel with a screw driver.
5. Put supplied square wrench onto visible square shaft. Release left lid lock by turning to the left and right lid lock by turning to the right. Relief lock by pressing down the lid.

Lid can be opened.

Attention!

The lid may only be unlocked and opened when the rotor is at standstill.

8.5.5 Problems with the Centrifuge?

Please contact your supplier for support or in the event of malfunctions and for supply of spare parts.

8. Appendix:

8.6 Error Codes

Error no.	Kind of error	Measures	Comment
1-62	Internal error	<ul style="list-style-type: none">• let slow down• power off/on	
69-77	EEPROM error	<ul style="list-style-type: none">• let slow down• power off/on	ATTENTION: Saved curves and programs could have been deleted.
81	Rotor spins with open cover	<ul style="list-style-type: none">• let slow down• close lid• power off/on	
82-83	Lid does not open	<ul style="list-style-type: none">• power off• emergency lid release	
84	Excess temperature heat sink	<ul style="list-style-type: none">• let cool down• provide for better ventilation• power off/on	
85	Excess temperature centrifuge chamber	<ul style="list-style-type: none">• let cool down• provide for better ventilation• power off/on	
86-89	Refrigerator doesn't cool down to set temperature	<ul style="list-style-type: none">• provide for better ventilation• increase set temperature	
90-96	Sensor defective	<ul style="list-style-type: none">• power off/on	
98	Faulty rotor identification	<ul style="list-style-type: none">• check rotor	
99	Incorrect rotor	<ul style="list-style-type: none">• check rotor and set rotor resp. bucket identification	

Should it not be possible to repair the failure, please contact service.

8.7 Speed-RCF-Diagram

An additional help is the enclosed Speed-RCF-Diagram.

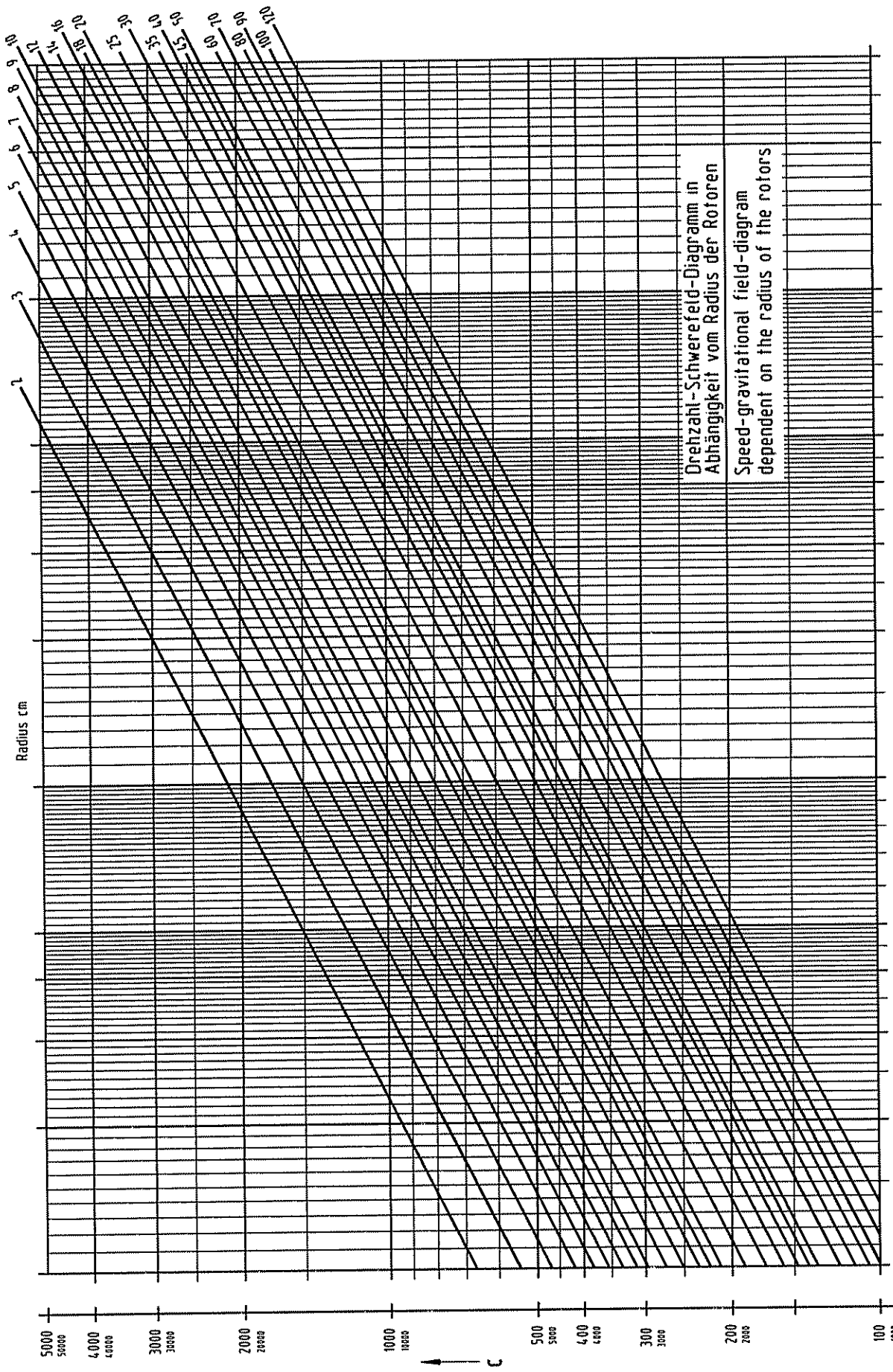

Drehzahl-Schwerefeld-Diagramm in
 Abhängigkeit vom Radius der Rotoren
 Speed-gravitational field-diagram
 dependent on the radius of the rotors

Radius cm

g

5000
4000
3000
2000
1000
500
400
300
200
100

10 20 30 40 50 70 100 200 300 400 500 1000 2000 3000 4000 5000 10000 20000 30000

8. Appendix:

8.8 Declaration of Decontamination / Return Declaration

The following declarations serve for keeping safety and health of our employees. Fill in the forms and attach them when returning centrifuges, accessories and spare parts. Please understand that we cannot carry out any work before we have the declarations. (We recommend to make **several copies of this page.**)

8. Appendix:



!!! Attention – This form must be glued on outside of the box !!!

Return declaration

	YES	NO
Decontamination declaration inside :		
Unit / component contaminated :		
Unit / component unused (new) :		

!!! Attention – This form must be glued on outside of the box !!!



Please make some copies before removing this page.

8. Appendix:



Declaration of Decontamination of Centrifuges, Accessories and Spare Parts

This declaration may only be filled in and signed by authorised staff.



Repair Order dtd. : _____
Order No. : _____
Type of unit : _____ Serial No. : _____
Type of unit : _____ Serial No. : _____
Type of unit : _____ Serial No. : _____
Type of unit : _____ Serial No. : _____
Accessories : _____

Is the equipment free from harmful substances ? YES NO

If not, which substances have come into contact with the equipment?

Name of the substances : _____

Remarks (e.g to be touched with gloves only) ; _____

General characteristics of the substances :

Corrosive	<input type="radio"/>	Explosive	<input type="radio"/>
Biologically hazardous	<input type="radio"/>	Radioactive	<input type="radio"/>
Toxic	<input type="radio"/>		

In combination with which substances may hazardous mixtures develop?

Name of the substances : _____

Has the equipment been cleaned before shipment? YES NO

Is the equipment decontaminated and not harmful to health? YES NO

Prior to repair, radioactively contaminated components must be decontaminated according to the valid regulations for radiation protection.

Legally Binding Declaration

I / we hereby declare that the information on this declaration are correct and complete.

Company / Institute : _____

Street : _____

Postcode, City : _____

Tel. : _____ FAX : _____

Name : _____

Date : _____ Stamp : _____

Signature : _____



Please make some copies before removing this page.

Program Data:

8.9 Program No.:

Used for

.....
.....
.....
.....

Alteration:

.....
.....

by:

.....

Date:

.....

Speed

.....

Gravitational field

.....

Rotor

.....

Bucket

.....

Made on:

.....

by:

.....

Curve Data:

8.10 Curve No.:

Interval No.:	Type	Acceleration time	Speed
1	quad/lin secrpm
2	lin/99 secrpm
3	lin/99 secrpm
4	lin/99 secrpm
5	lin/99 secrpm
6	lin/99 secrpm
7	lin/99 secrpm
8	lin/99 secrpm
9	lin/99 secrpm
10	99 secrpm

Used in program no.: for acceleration [] / for deceleration []

Used in program no.: for acceleration [] / for deceleration []

Used in program no.: for acceleration [] / for deceleration []

Used in program no.: for acceleration [] / for deceleration []

Used in program no.: for acceleration [] / for deceleration []

Used in program no.: for acceleration [] / for deceleration []

Used in program no.: for acceleration [] / for deceleration []

Used in program no.: for acceleration [] / for deceleration []

Used in program no.: for acceleration [] / for deceleration []

Used in program no.: for acceleration [] / for deceleration []

4.1 Operating Panel

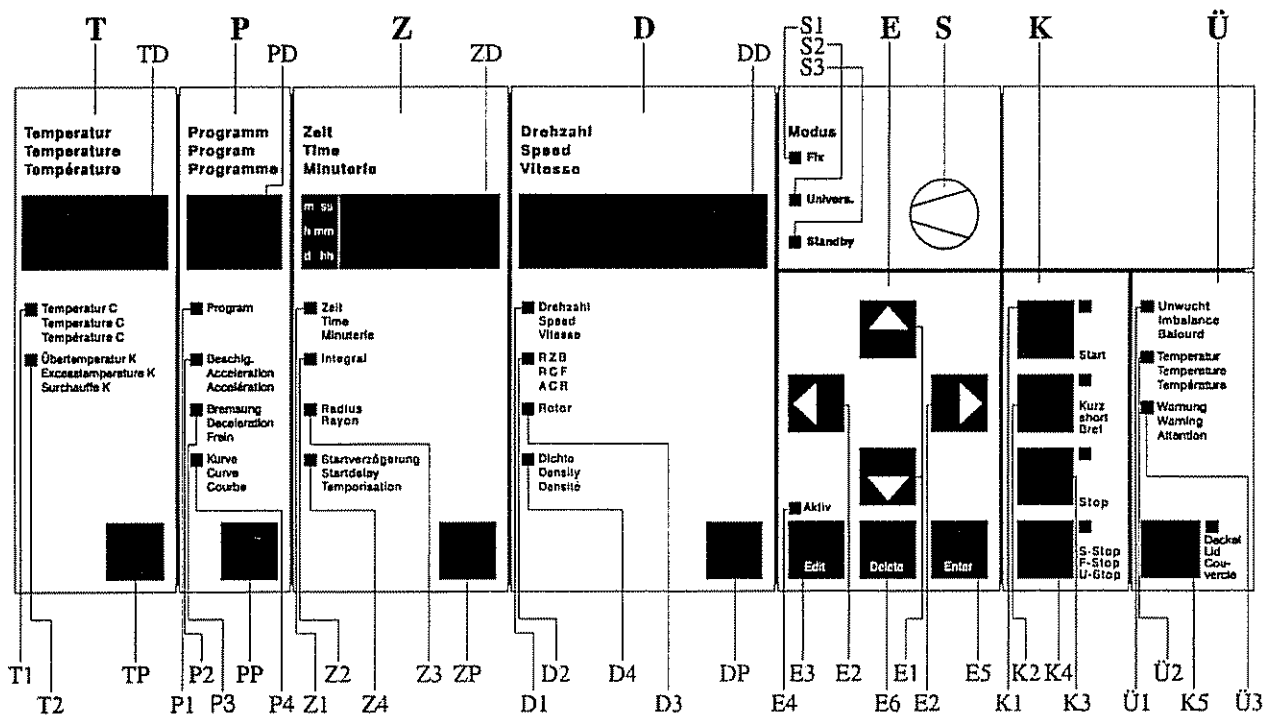

T	Temperature panel	D	Speed panel	Ü	Monitoring panel
TP	Temperature parameter key	DP	Speed parameter key	Ü1	Monitoring-LED imbalance
TD	Temperature display	DD	Speed display	Ü2	Monitoring-LED temperature
T1	Temperature-LED	D1	Speed-LED	Ü3	Monitoring-LED warning
T2	Excess temperature-LED	D2	RCF-LED	K5	Lid-key
P	Program panel	D3	Rotor-LED	E	Input panel
PP	Program parameter key	D4	Density-LED	E1	Alteration keys
PD	Program panel display	E	Input panel	E2	Cursor keys
P1	Program-LED	E1	Alteration keys	E3	Edit-key
P2	Acceleration-LED	E2	Cursor keys	E4	Edit-Aktiv-LED
P3	Deceleration-LED	E3	Edit-key	E5	Enter-key
P4	Curve-LED	E4	Edit-Aktiv-LED	E6	Delete-key
Z	Time panel	E5	Enter-key	K	Command panel
ZP	Time parameter key	E6	Delete-key	K1	Start-key
ZD	Time display	K	Command panel	K2	Short-key
Z1	Time-LED	K1	Start-key	K3	Stop-key
Z2	Integral-LED	K2	Short-key	K4	Faststop-key
Z3	Radius-LED	K3	Stop-key		
Z4	Start delay-LED	K4	Faststop-key		
				S	Key-operated switch
				S1	Fix-Mode-LED
				S2	Universal-Mode-LED
				S3	Standby-Mode-LED